

REV	DESCRIPTION	DATE
A	Initial Release	10.04.23

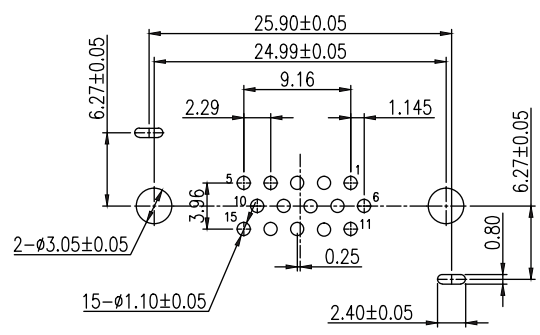
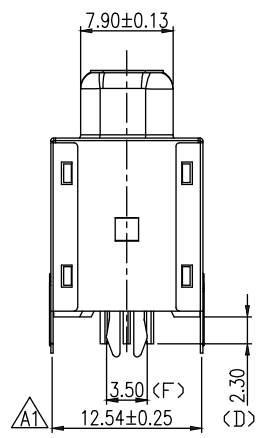
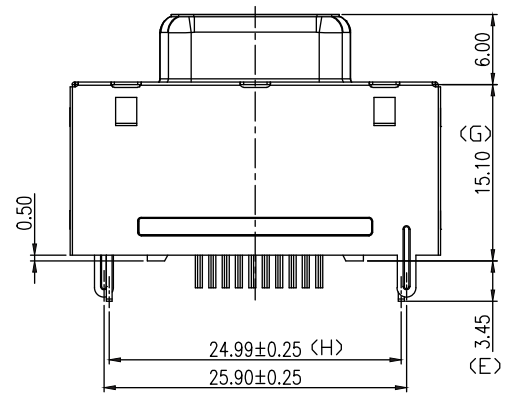
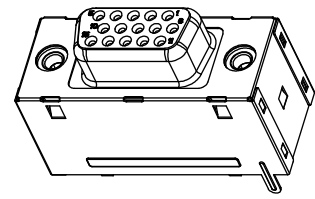
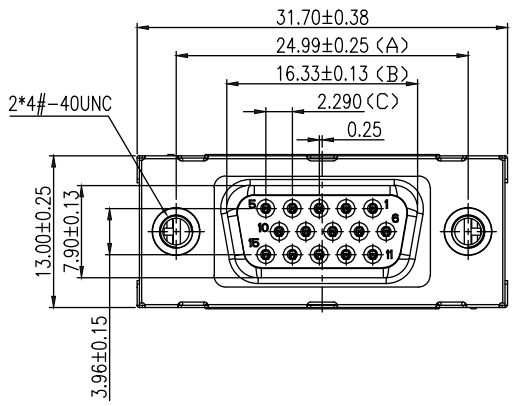

RECOMMEND PCB LAYOUT(TOP VIEW)  
 PCB THICKNESS:1.60mm.  
 TOLERANCE:±0.05mm.  
 INSPECTION DIMENSION:(A)~(H)

**SPECIFICATIONS**

- D-SUB
- 1.1 Voltage: 250 VAC(RMS) Max.
- 1.2 Current Rating: 3 Ampere per Contact
- 1.3 Contact Resistance: 25 Milliohms Max.
- 1.4 Insulation Resistance: 5000 Megohms Min.
- 1.5 Dielectric Withstanding Voltage: 1000V AC(RMS)
- 1.6 Total Mating Force: 6.0 Kgf Max.
- 1.7 Total Unmating Force: 1.0 Kgf Min.
- 1.8 Operating Temperature: -55°C to +85°C

**NOTES**

- MATERIAL:**  
 Housing:PBT, UL 94V-0, Color:Blue.  
 Terminal:Copper Alloy.  
 Shell:SPCC.  
 Shield:Copper Alloy.  
 Boardlock:Steel.
- FINISH:**  
 Terminal:Gold Plated over Nickel at Contact Area.  
 Tin Plated over Nickel at Solder Ared.  
 Shell:Nickel Plated.  
 Shield:Nickel Plated.  
 Boardlock:Tin Plated.
- This Product is LEAD-FREE & GP Compliance Product.

**HDSH XXX XXXXXXXXG2**

<b>SERIES NO.</b>	G: IT'S COMPLIANT WITH GP
<b>NUMBER OF POSITION</b>	<b>INSULATOR MATERIALS</b>
1D: 9-POS. MALE (15.1mm)	1: PBT
2D: 9-POS. MALE (14.6mm)	3: PA9T
3D: 9-POS. MALE (13.0mm)	4: PA6T
4D: 9-POS. MALE (11.6mm)	<b>COLOR STYLE</b>
5D: 9-POS. MALE (10.0mm)	1: ALL BLACK
6D: 9-POS. MALE (8.5mm)	2: ALL BLUE
1H: 15-POS. HI-DEN FEMALE (15.1mm)	<b>FLANGE MOUNTING OPTION</b>
2H: 15-POS. HI-DEN FEMALE (14.6mm)	1: #4-40 THREADED HOLE
3H: 15-POS. HI-DEN FEMALE (13.0mm)	L: #4-40 THREADED HOLE WITH #4-40UNC SCREWLOCK INSTALLED (4.8x9.5)
4H: 15-POS. HI-DEN FEMALE (11.6mm)	M: #4-40 THREADED HOLE WITH #4-40UNC SCREWLOCK BULK-PACKED (4.8x9.5)
5H: 15-POS. HI-DEN FEMALE (10.0mm)	<b>BOARD MOUNTING OPTION</b>
6H: 15-POS. HI-DEN FEMALE (8.5mm)	2: 2-FINGER BOARDLOCK
<b>CONTACT STYLE</b>	8: HOLE BOARDLOCK
S: SOCKET	<b>FRONT SHELL FINISH</b>
P: PLUG	1: TIN
<b>CONTACT MATERIALS</b>	2: NICKEL
1: BRASS	
<b>CONTACT FINISH</b>	
1: G/F BRIGHT TIN	
3: 15u" GOLD BRIGHT TIN	
4: 30u" GOLD BRIGHT TIN	

				DRAWN BY		TOMMY	
				CHECKED			
TITLE:		D-SUB 15 FEMALE STRAIGHT DIP MOUNT PLASTIC 15.1mm				APPROVED	
PART NO:		HDSH XXX XXXXXXXXG2				DRAWING NO.	
SCALE		1:1	REV	A	UNIT	mm	

UNLESS OTHERWISE SPECIFIED TOLERANCE mm:  
 .0 = ±0.38  
 .00 = ±0.25  
 .000 = ±0.13  
 ANGULAR ±2°