

REV.	DESCRIPTION	DATE
A	Initial Release	05.12.29

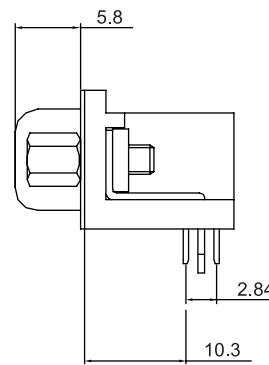
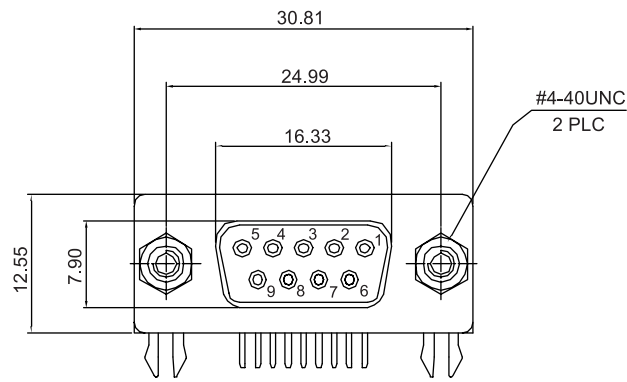

ELECTRICAL CHARACTERISTICS

Contact Current Rating:3Amperes.
 Dielectric Withstanding Voltage:AC 500V @50sec. rms
 Insulation Resistance:100Megaohms Minimum at DC 500V.
 Contact Resistance:25 Milliohms Maximum.
 Operating Temperature:-55°C to +105°C

MECHANICAL CHARACTERISTIC

Contact Insertion Force:341g, Maximum.
 Contact Separation Force:21g, Minimum.

MATERIALS

Contact :Copper Alloy.
 Insulator:PBT UL 94V-0 Rated.
 Shell:SPCC.
 Z-Piece:Copper Alloy.
 Rivet:Copper Alloy or Fe.
 Screw:Copper Alloy.

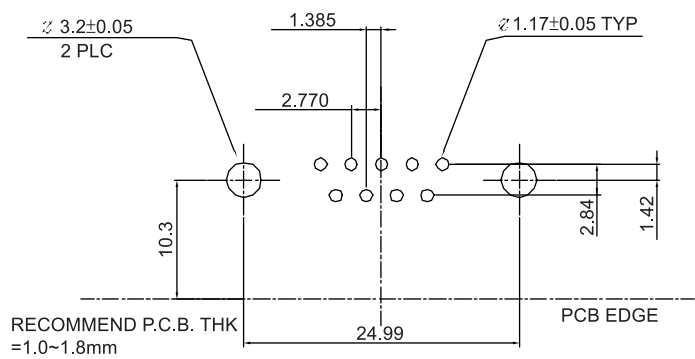
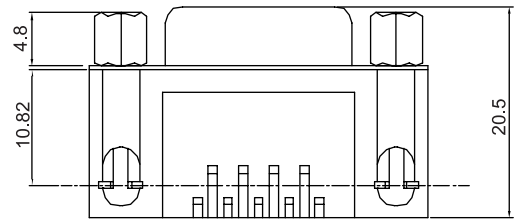

RoHS Compliant

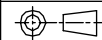
DWG NO:		MATERIAL:		 PANSTRONG COMPANY LTD.
MODEL NO:		FINSH:		
UNIT:	SIZE:	COLOR:		PART NAME:
		DR: TOMMY		D-SUB 9F RIGHT ANGLE
TOLERANCE UNSPECIFIED		CHK:	PART NO:	DB09F0101KG-L1E
.x	±0.3	APP:	SCALE:	REV: A
.xx	±0.20		SHEET: 1 of 1	
.xxx	±0.100			
ANG	±1°			