

REV	DESCRIPTION	DATE
A	Initial Release	06'.04.12

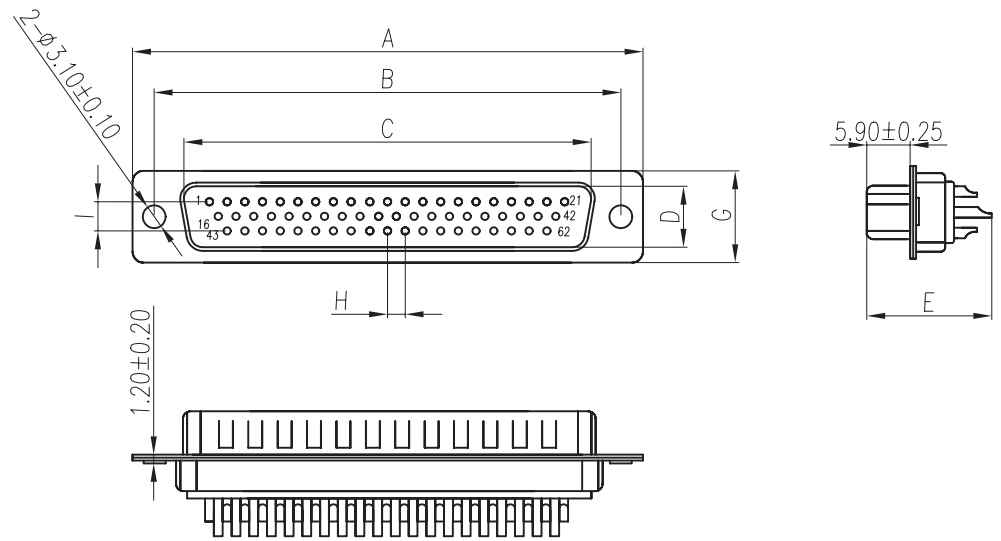

- 1.Material:
- 1.1 Insulator: P.B.T UL 94-V0 rated.
  - 1.2 Contact: Brass,t=0.20mm.
  - 1.3 Shell: Cold rolled steel,t=0.40mm.
- 2.Specification:
- 2.1 Current rating: 1 A Max.
  - 2.2 Dielectric withstanding voltage: 500 V(ac) for 1 minute.
  - 2.3 Contact resistance: 30 mΩ Max.
  - 2.4 Insulation resistance: 1000 MΩ Min at DC 500V.
  - 2.5 Temperature range: -55°C~+105°C

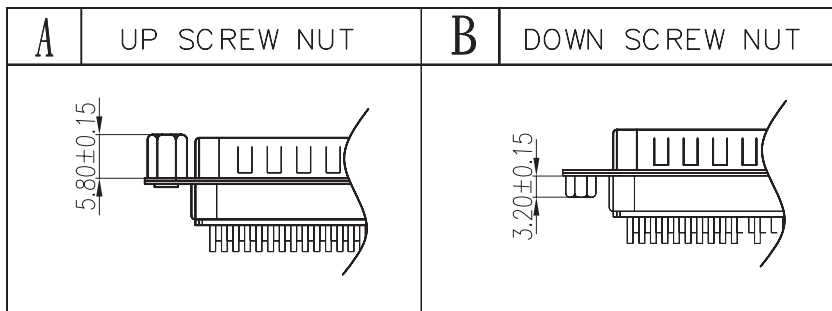

Part No. HD xx M01x xx x E  
                  1      2 3 4

- 1. Contact Positions: 15, 26, 44, 62
- 2. Insulator: B:Blue, K:Black, W:White
- 3. Contact Plating: 00:Selective Flash Gold  
                          15:Selective 15u" Gold  
                          30:Selective 30u" Gold
- 4. Shell Plating: Blank:Front Nickel and Rear Tin  
                          T:Both Front and Rear Tin

No.	Part Name	Q'ty	Material	Remarks & Thickness	Finish
6	8.0 Nut	2	Brass	H4.75*8.0	Nickel Plated
5	3B Nut	2	Brass	H4.75*4.75	Nickel Plated
4	Back-shell	1	Cold Rolled Steel	T=0.40mm	Tin Plated
3	Front-shell	1	Cold Rolled Steel	T=0.40mm	Nickel Plated
2	Contact	15~62	Brass	T=0.20mm	Gold Flashed
1	Housing	1	P.B.T	UL 94-V0	Black/Blue/White

Pos. No.	A±0.25	B±0.25	C±0.25	D±0.25	E±0.25	G±0.25	H±0.20	I±0.20
15	30.80	25.00	16.92	8.30	17.00	12.60	2.29	3.96
26	39.20	33.32	25.25	8.30	17.00	12.60	2.29	3.96
44	53.05	47.04	38.96	8.30	17.00	12.60	2.29	3.96
62	69.40	63.50	55.42	8.30	17.00	12.60	2.41	3.96

TOLERANCE UNSPECIFIED  
.x ±0.3  
.xx ±0.20  
.xxx ±0.100  
ANG. ±1°

	PANSTRONG COMPANY LTD.			DRAWN BY	TOMMY
				CHECKED	
TITLE:	D-SUB HDD SOLDER(M)			APPROVED	
PART NO:	HDxxM01xxxxE			DRAW NO	
File Number:					
SCALE	1:1	REV	A	UNIT	mm