

REV	DESCRIPTION	DATE
A	Initial Release	01.05.04

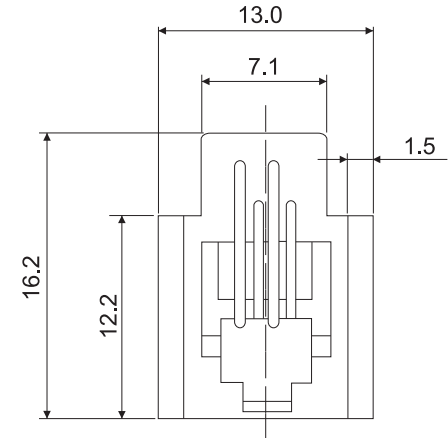
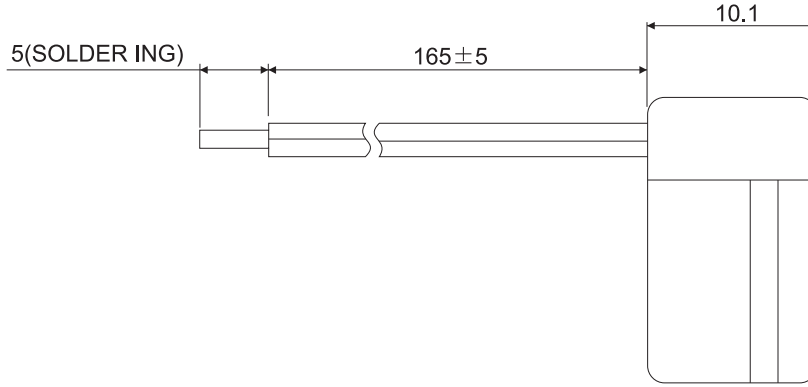
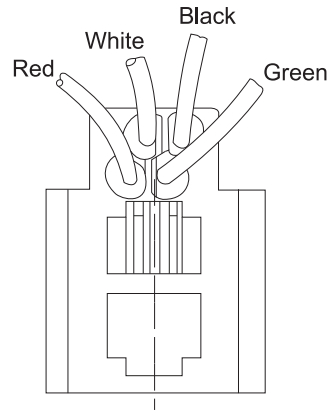

**NOTE:**

- 1.MATERIAL:HOUSING-ABS RESIN UL94V-0  
CONTACT-0.46mm DIAMETER  
PHOS-BRONZE PLATED WITH HARD GOLD  
TERMINAL-0.4mm THICKNESS 3/4 HARD  
BRASS, 2.5mm <SLODER(TIN-LEAD)
- 2.CAVITY CONFIRMS TO FCC ULES AND REGULATION PARTS68, SUBPART F

**ELECTRICAL CHARACTERISTICS:**  
INSULATION RESISTANCE-500M HOMS MIN.  
WITHSTAND VOLTAGE-AC 500V 1 MINUTE  
CONTACT RESISTANCE-50m OHMS MAX.  
RATING CURRENT-1.5A MAX.

**MECHANICAL CHARACTERISTICS:**  
MATING FORCE-350 Grams--2 Wire lead  
500 Grams--4 Wire lead  
RETENTION STRENGTH-7.7kg(17 Lbs.) BETWEEN  
JACK AND PLUG  
CRIMP TENSILE STRENGTH-2.27kg(5.0 Lbs)

 <b>PANSTRONG COMPANY LTD.</b>				DRAWN BY		TOMMY	
				CHECKED			
TITLE:		616MS WIRED PHONE JACK				APPROVED	
PART NO:						DRAW NO	
File Number:							
SCALE	/	REV	A	UNIT	mm	