

REV	DESCRIPTION	DATE
A	Initial Release	05'.07.08

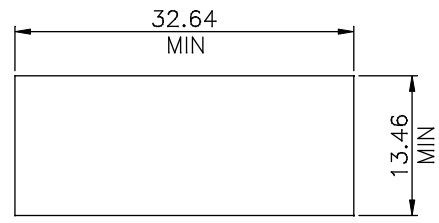

RECOMMENDED PANEL CUTOUT

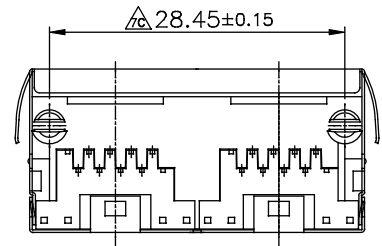
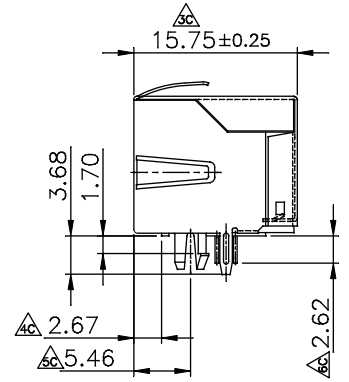
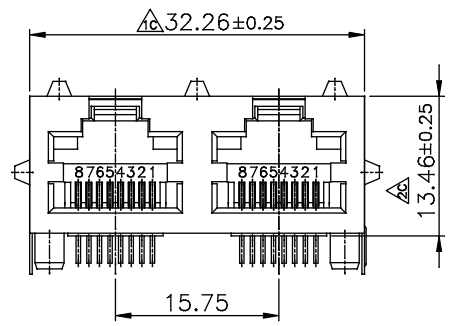
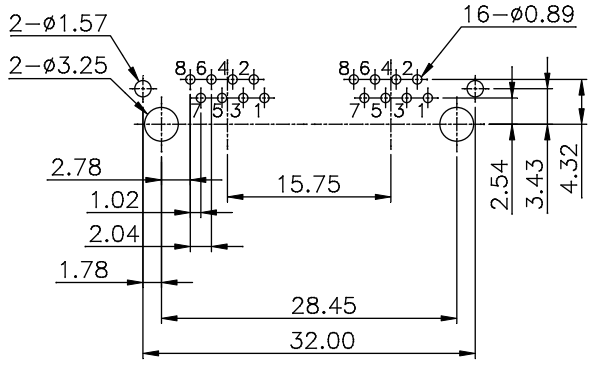

P.C.B LAYOUT/TOP VIEW

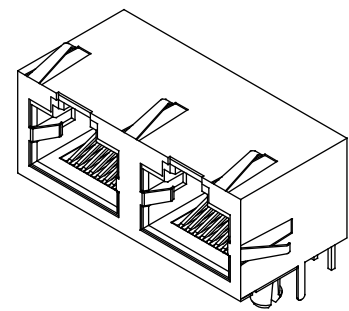

MATERIALS:

PLASTIC HOUSING: THERMOPLASTIC PBT or HIGH TEMP. PLASTIC FR52  
 FLAMMABILITY RATING UL 94V-0.

CONTACTS: PHOSPHOR BRONZE

PLATING: GOLD PLATING OVER NICKEL IN CONTACT,  
 TIN PLATING OVER NICKEL IN SOLDER AREA.

SHIELD: BRASS PLATING NICKEL ALLOY.

PART NO. MJS2L38801KxxST2

Housing Material:  
 S: PBT H: FR52

Contact Gold Plating:  
 06: 6u" Selective Gold  
 :  
 50: 50u" Selective Gold

※ △ : Q.C. Dimensions

TOLERANCE	
.XXX	±0.10
.XX	±0.25
.X	±0.38
X	±0.50
ANG	±3°

PANSTRONG COMPANY LTD.				DRAWN BY		TOMMY	
				CHECKED			
TITLE:		2PORT 8P8C JACK		APPROVED			
PART NO:		MJS2L38801KxxST2		DRAW NO			
File Number:							
SCALE	2:1	REV	A	UNIT	mm		