

REV	DESCRIPTION	DATE
A	Initial Release	05.11.04

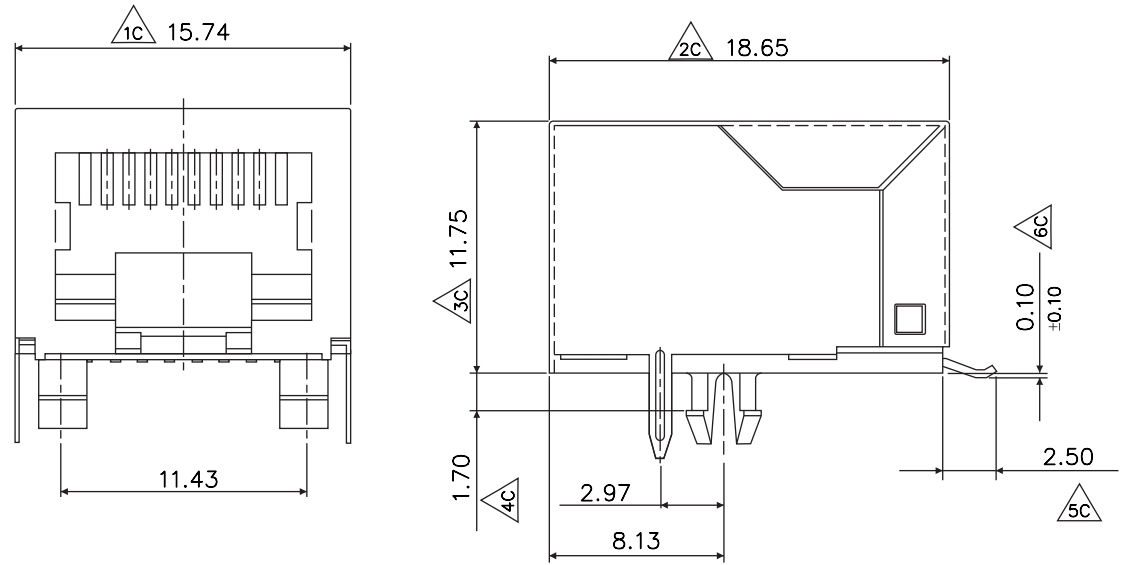

MATERIALS:
 PLASTIC HOUSING: HIGH TEMP. THERMOPLASTIC
 FLAMMABILITY RATING UL 94V-0
 CONTACTS: PHOSPHOR BRONZE
 PLATING: GOLD PLATING OVER NICKEL IN CONTACT.
 TIN PLATING OVER NICKEL IN SOLDER AREA.
 SHIELD: BRASS PLATING NICKEL ALLOY.

PART NO.
 MJS880301Kxx
 Contact Gold Plating:
 06: 6u" Selective Gold
 :
 50: 50u" Selective Gold

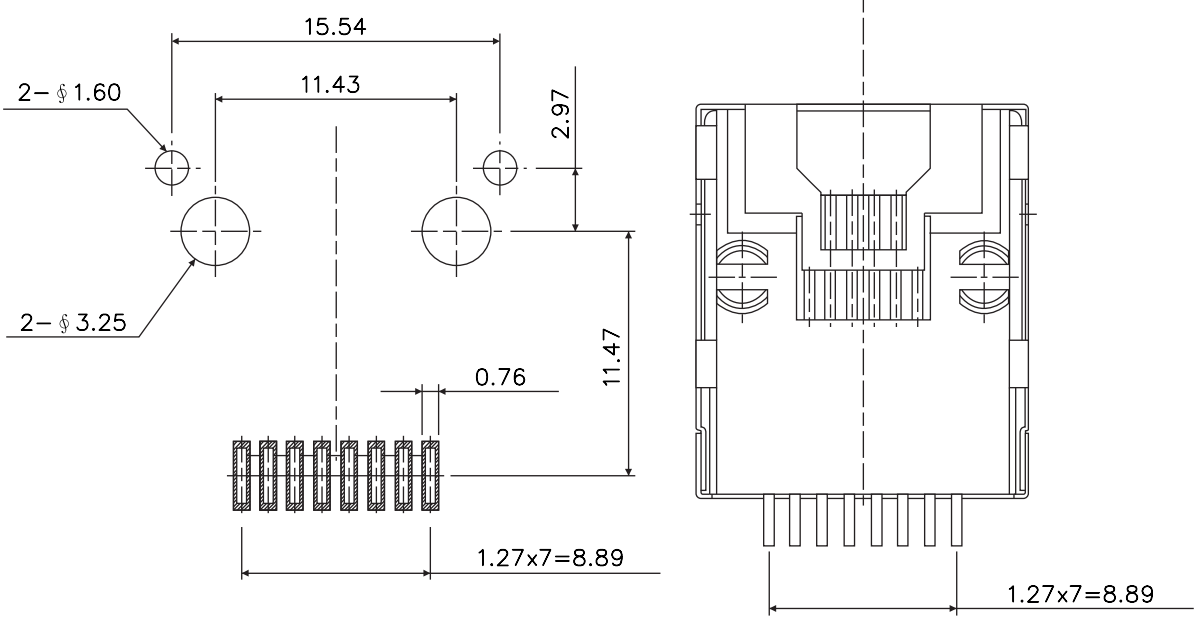

PCB LAYOUT/TOP VIEW

PANSTRONG COMPANY LTD.				DRAWN BY		TOMMY	
				CHECKED			
TITLE:		8P8C KS SMT JACK		APPROVED			
PART NO:		MJS880301Kxx		DRAW NO			
File Number:							
SCALE	/	REV	A	UNIT	mm		