

| REV | DESCRIPTION | DATE |
|-----|-----------------|-----------|
| A | Initial Release | 06'.10.13 |

FINISH (PLATING THICKNESS IN MICRO-INCHES)

1. BRASS PER QQ-B-626
2. NICKEL PL 70 MIN THICK OVER COPPER STRIKE
3. GOLD PL 3 MIN OVER NICKEL PL 70 MIN THICK OVER COPPER STRIKE
4. TEFLON MIL-P-19468
5. PHOSPHOR BRONZE PER QQ-B-750

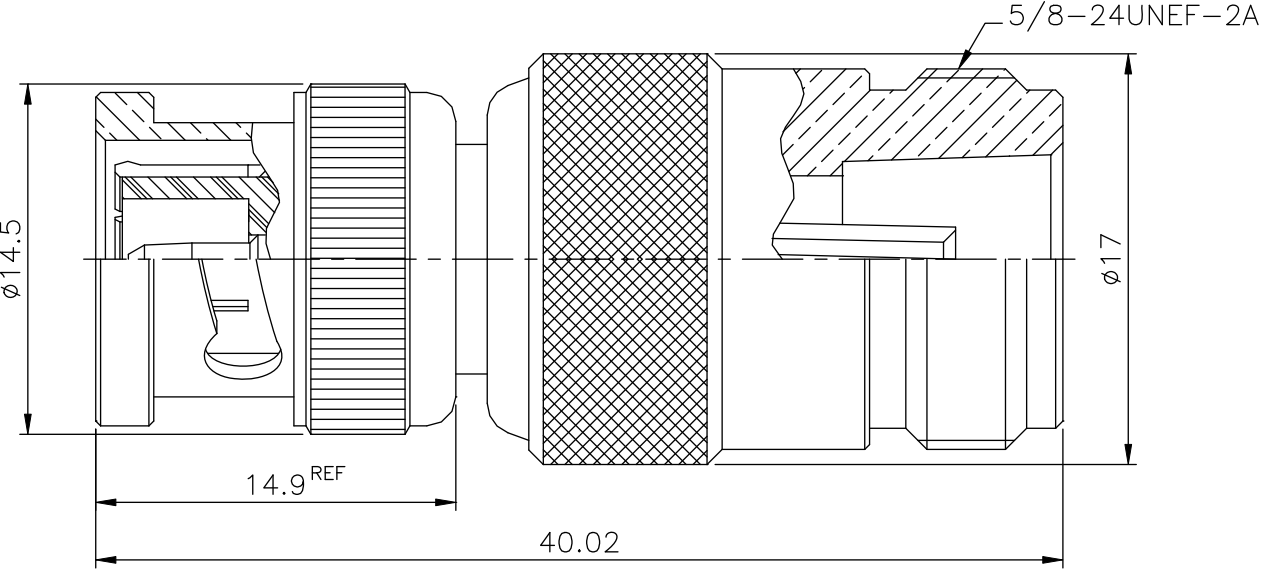

| | | |
|-------------|----------|--------|
| SHELL | NOTE 1 | NOTE 2 |
| GASKET | SILICONE | RED |
| C RING | SS41 | NOTE 2 |
| SPRING | SK5 | NOTE 2 |
| WASHER | SS41 | NOTE 2 |
| BODY | NOTE 1 | NOTE 2 |
| CONTACT PIN | NOTE 5 | NOTE 3 |
| INSULATOR | NOTE 4 | WHITE |
| BODY | NOTE 1 | NOTE 2 |
| DESCRIPTION | MATERIAL | FINISH |

RoHS COMPLIANT

UNLESS OTHERWISE SPECIFIED TOLERANCES
 0.5-0.9 = ±0.2
 >0.9-30 = ±0.4
 >30-120 = ±0.6
 >120-315 = ±1
 >315-1000 = ±1.6
 ANGLES = ±5°

| | | | | | | | |
|------------------------|--|----------------------------|-----|----------|------|-------------|--|
| PANSTRONG COMPANY LTD. | | | | DRAWN BY | | TOMMY | |
| | | | | CHECKED | | | |
| TITLE: | | BNC PLUG to N JACK ADAPTOR | | | | APPROVED | |
| PART NO: | | BM/NF02N | | | | DRAWING NO. | |
| SCALE | | 3:1 | REV | A | UNIT | mm | |