

REV	DESCRIPTION	DATE
A	Initial Release	06'.08.28

RoHS COMPLIANT

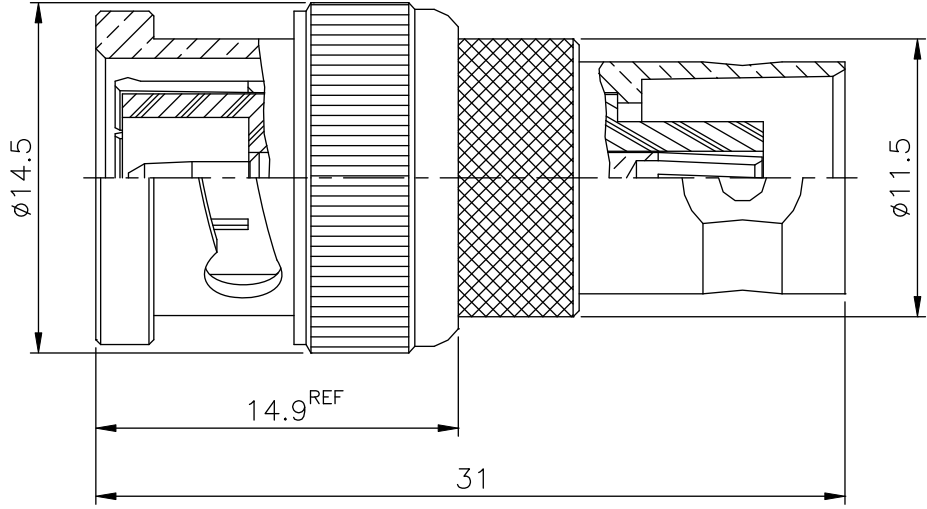

FINISH (PLATING THICKNESS IN MICRO-INCHES)
 1. BRASS PER QQ-B-626
 2. NICKEL PL 70 MIN THICK OVER COPPER STRIKE
 3. GOLD PL 3 MIN OVER NICKEL PL 70 MIN THICK OVER COPPER STRIKE
 4. PHOSPHOR BRONZE PER QQ-B-750

SHELL	NOTE 1	NOTE 2
GASKET	SILICONE	RED
C RING	SS41	NOTE 2
SPRING	SK5	NOTE 2
WASHER	SS41	NOTE 2
INSULATOR	DELRIN	WHITE
CONTACT PIN	NOTE 4	NOTE 3
INSULATOR	DELRIN	WHITE
BODY	NOTE 1	NOTE 2
DESCRIPTION	MATERIAL	FINISH

UNLESS OTHERWISE SPECIFIED
 TOLERANCES
 0.5-6 = ±0.2
 >6-30 = ±0.4
 >30-120 = ±0.6
 >120-315 = ±1
 >315-1000 = ±1.6
 ANGLES = ±5°

PANSTRONG COMPANY LTD.		DRAWN BY	TOMMY
		CHECKED	
TITLE:	BNC PLUG to JACK ADAPTOR		APPROVED
PART NO:	BM/BF02N		DRAWING NO.
SCALE	3:1	REV	A
UNIT	mm		