

REMARK: RoHS COMPLIANT

REV	DESCRIPTION	DATE
A1	Initial Release	07'.03.30

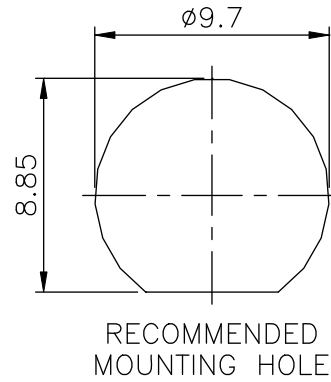
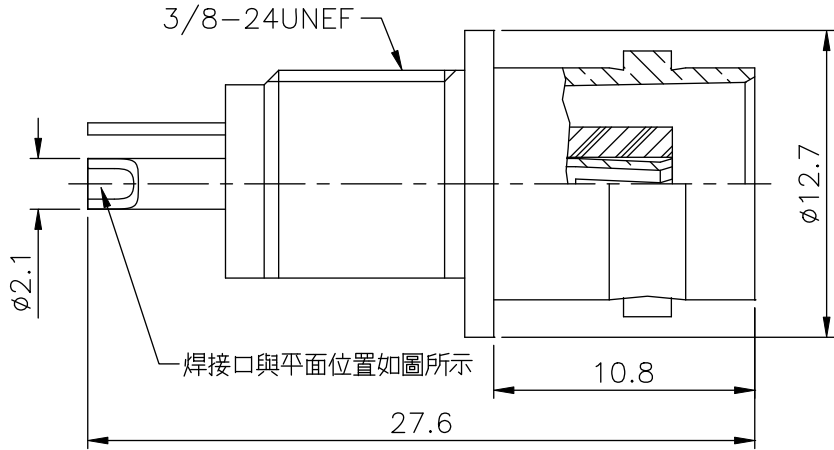

- FINISH (PLATING THICKNESS IN MICRO-INCHES)
1. BRASS PER QQ-B-626
 2. GOLD PL 3 MIN OVER NICKEL PL 70 MIN THICK OVER COPPER STRIKE
 3. GOLD PL FLUSH OVER NICKEL PL 70 MIN THICK OVER COPPER STRIKE
 4. PHOSPHOR BRONZE PER QQ-B-750
 5. NICKEL PL 70 MIN THICK OVER COPPER STRIKE

NUT	NOTE 1	NOTE 2
WASHER	SS41	NOTE 2
CONTACT PIN	NOTE 4	NOTE 3
INSULATOR	ABS	WHITE
LOCK RING	NOTE 1	NOTE 5
GROUNDING TAG	NOTE 1	NOTE 2
BODY	NOTE 1	NOTE 2
DESCRIPTION	MATERIAL	FINISH

1. MAX. PANEL THICKNESS=2.4mm

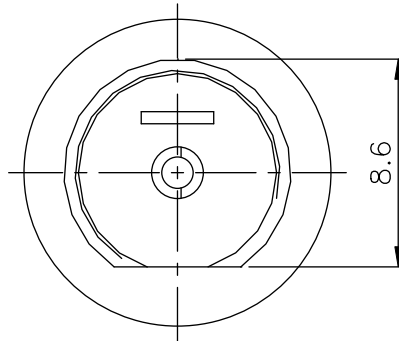
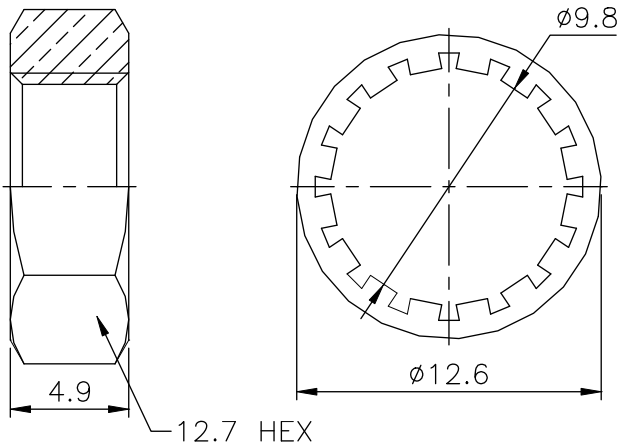

UNLESS OTHERWISE SPECIFIED TOLERANCES

0.5-6	= ±0.2
>6-30	= ±0.4
>30-120	= ±0.6
>120-315	= ±1
>315-1000	= ±1.6
ANGLES	= ±5°

PANSTRONG COMPANY LTD.				DRAWN BY		TOMMY	
				CHECKED			
TITLE:		BNC ISOLATED BULKHEAD RECEPT JACK(50 ohms)				APPROVED	
PART NO:		BF02N0205SO				DRAW NO	
File Number:							
SCALE	3:1	REV	A1	UNIT	mm		