

REV	DESCRIPTION	DATE
A	Initial Release	05'.12.02

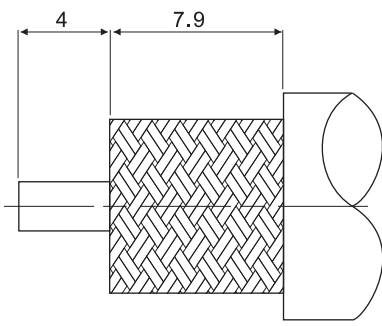

RECOMMENDED
CABLE STRIPPING DIM'S

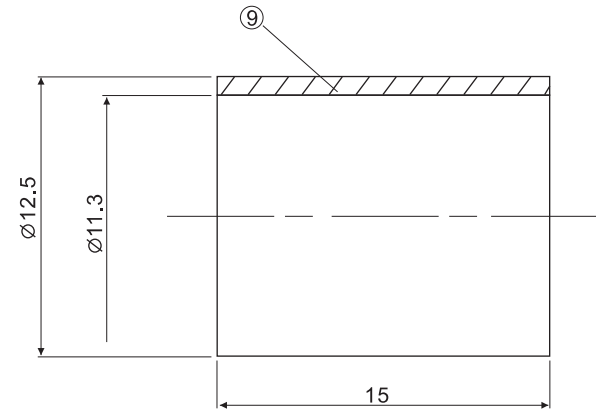

- 1. CRIMPED FERRULE
HEX CRIMP SIZE .429"
- 2. CRIMPED CONTACT PIN
HEX CRIMP SIZE .105" OR SOLDER

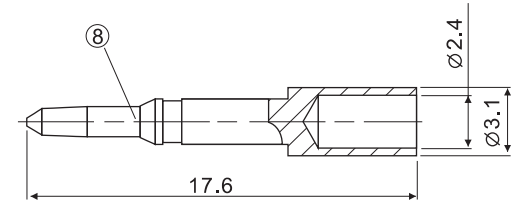

- FINISH (PLATING THICKNESS IN MICRO-INCHES)
- 1. BRASS PER QQ-B-626
 - 2. NICKEL PL 70 MIN THICK OVER COPPER STRIKE
 - 3. BRASS JIS H3250, C 2700
 - 4. BOLD PL 3 MIN OVER NICKEL PL 70 MIN THICK OVER COPPER STRIKE

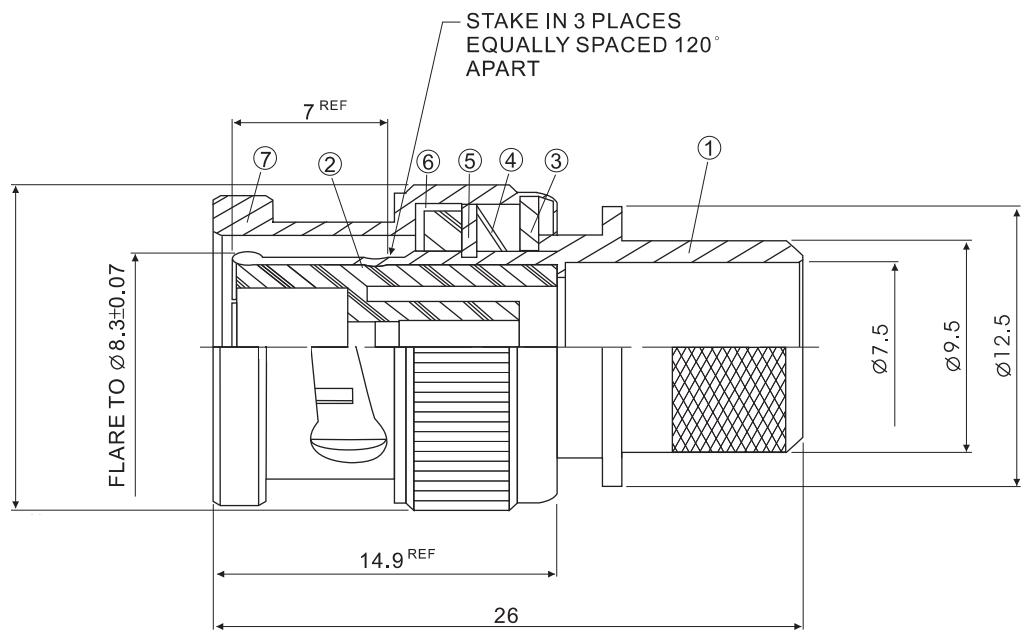

NO	DESCRIPTION	MATERIAL	FINISH	Q'TY
9	FERRULE	NOTE 3	NOTE 2	1
8	CONTACT PIN	NOTE 1	NOTE 4	1
7	SHELL	NOTE 1	NOTE 2	1
6	GASKET	RUBBER	RED	1
5	C RING	SS41	NOTE 2	1
4	WASHER	SK5	NOTE 2	1
3	WASHER	SS41	NOTE 2	1
2	INSULATOR	DELIRIN	WHITE	1
1	BODY	NOTE 1	NOTE 2	1

ROHS COMPLIANT

	PANSTRONG COMPANY LTD.			DRAWN BY	TOMMY
				CHECKED	
TITLE:	BNC CRIMP PLUG (FOR RG-213/U,B8267)			APPROVED	
PART NO:	BM02N0211-213			DRAWING NO.	
SCALE	/	REV	A	UNIT	mm

