

REV	DESCRIPTION	DATE
A1	Initial Release	06'.08.30

REMARK: RoHS COMPLIANT

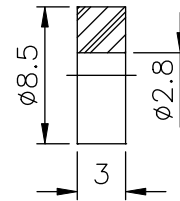
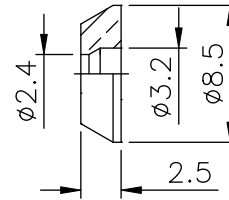
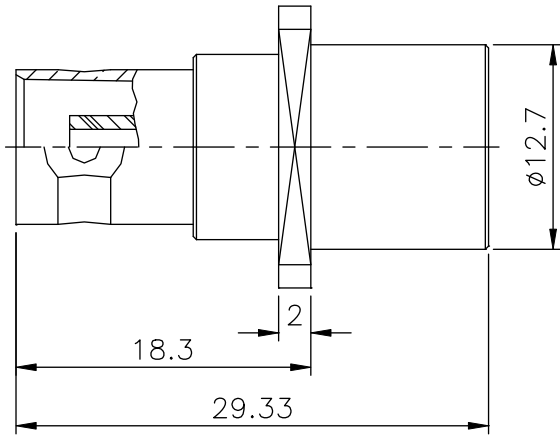
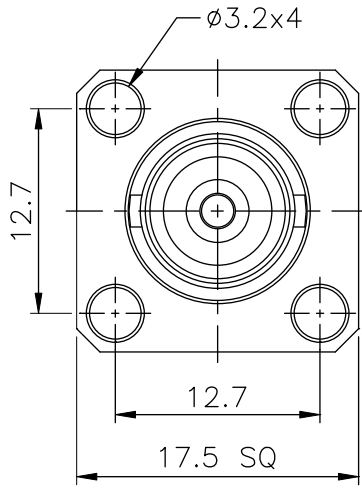

- FINISH (PLATING THICKNESS IN MICRO-INCHES)
1. BRASS PER QQ-B-626
 2. NICKEL PL 70 MIN THICK OVER COPPER STRIKE
 3. GOLD PL 3 MIN OVER NICKEL PL 70 MIN THICK OVER COPPER STRIKE
 4. PHOSPHOR BRONZE PER QQ-B-750

DESCRIPTION	MATERIAL	FINISH
NUT	NOTE 1	NOTE 2
WASHER	NOTE 1	NOTE 2
GASKET	RUBBER	ORANGE
BRAID HOLDER	NOTE 1	NOTE 2
CONTACT PIN	NOTE 4	NOTE 3
LOCK RING	NOTE 1	NOTE 2
INSULATOR	DELIRIN	WHITE
BODY	NOTE 1	NOTE 2
DESCRIPTION	MATERIAL	FINISH

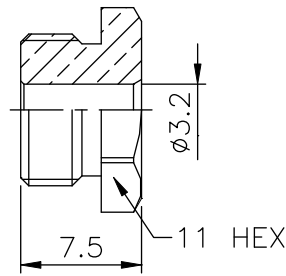
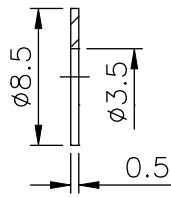
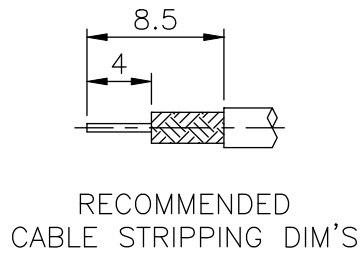

1. CRIMPED CONTACT PIN
SQ CRIMP SIZE .068" (1.72mm)

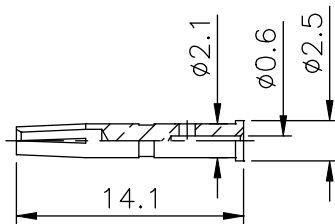

UNLESS OTHERWISE SPECIFIED TOLERANCES

0.5~6	= ±0.2
>6~30	= ±0.4
>30~120	= ±0.6
>120~315	= ±1
>315~1000	= ±1.6
ANGLES	= ±5°

PANSTRONG COMPANY LTD.				DRAWN BY		TOMMY	
				CHECKED			
TITLE:		BNC PANEL CLAMP JACK (FOR RG-174/U, 188A/U, 316/U)				APPROVED	
PART NO:		BF02N0212-06				DRAW NO	
File Number:							
SCALE	2:1	REV	A1	UNIT	mm		