

REMARK: RoHS COMPLIANT

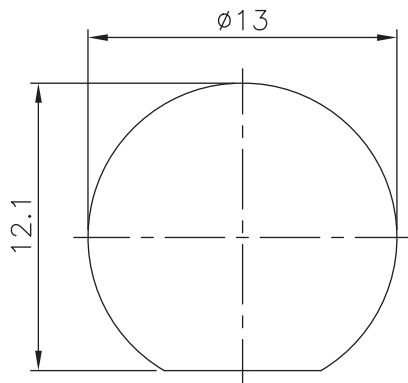
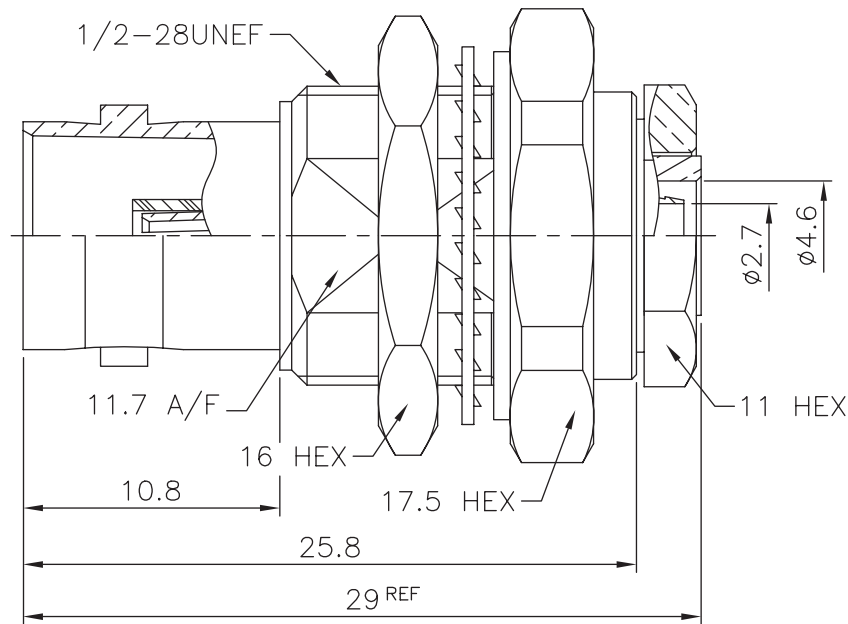

RECOMMENDED MOUNTING HOLE

UNLESS OTHERWISE SPECIFIED TOLERANCES

0.5~6	= ±0.2
>6~30	= ±0.4
>30~120	= ±0.6
>120~315	= ±1
>315~1000	= ±1.6
ANGLES	= ±5°

REV	DESCRIPTION	DATE
A1	Initial Release	07.04.20

FINISH (PLATING THICKNESS IN MICRO-INCHES)

1. BRASS PER QQ-B-626
2. NICKEL PL 70 MIN THICK OVER COPPER STRIKE
3. GOLD PL 30 MIN OVER NICKEL PL 70 MIN THICK OVER COPPER STRIKE
4. TEFLON MIL-P-19468
5. BERYLLIUM COPPER PER QQ-C-530
6. PHOSPHOR BRONZE PER QQ-B-750

NUT	NOTE 1	NOTE 2
WASHER	NOTE 6	NOTE 2
GASKET	RUBBER	ORANGE
NUT	NOTE 1	NOTE 2
BRAID HOLDER	NOTE 1	NOTE 2
CONTACT PIN	NOTE 5	NOTE 3
INSULATOR	NOTE 4	WHITE
BRAID HOLDER	NOTE 1	NOTE 2
INSULATOR	NOTE 4	WHITE
BODY	NOTE 1	NOTE 2
DESCRIPTION	MATERIAL	FINISH

PANSTRONG COMPANY LTD.				DRAWN BY		TOMMY	
				CHECKED			
TITLE:		BNC BULKHEAD CLAMP JACK				APPROVED	
PART NO:		BF02N0211-05				DRAW NO	
File Number:							
SCALE	3:1	REV	A1	UNIT	mm		