

REMARK: RoHS COMPLIANT

REV	DESCRIPTION	DATE
A1	Initial Release	07.03.28

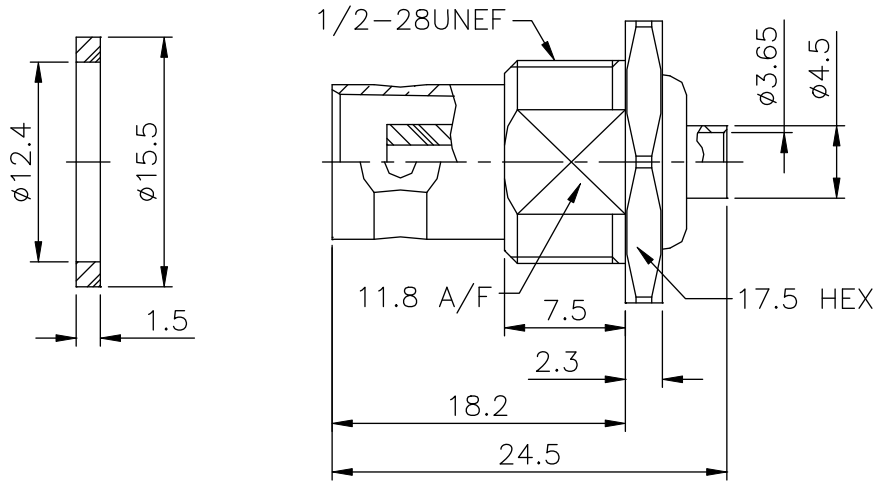

- FINISH (PLATING THICKNESS IN MICRO-INCHES)
1. BRASS PER QQ-B-626
 2. NICKEL PL 70 MIN THICK OVER COPPER STRIKE
 3. GOLD PL 3 MIN OVER NICKEL PL 70 MIN THICK OVER COPPER STRIKE
 4. TEFLON MIL-P-19468
 5. PHOSPHOR BRONZE PER QQ-B-750

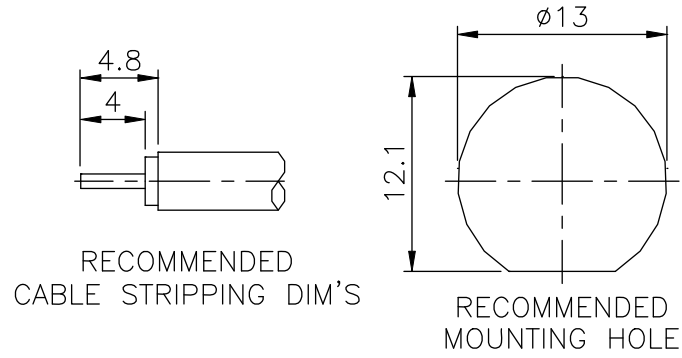

NUT	NOTE 1	NOTE 2
WASHER	SS41	NOTE 2
GASKET	RUBBER	ORANGE
CONTACT PIN	NOTE 5	NOTE 3
BRAID HOLDER	NOTE 1	NOTE 3
INSULATOR	NOTE 4	WHITE
BODY	NOTE 1	NOTE 2
DESCRIPTION	MATERIAL	FINISH

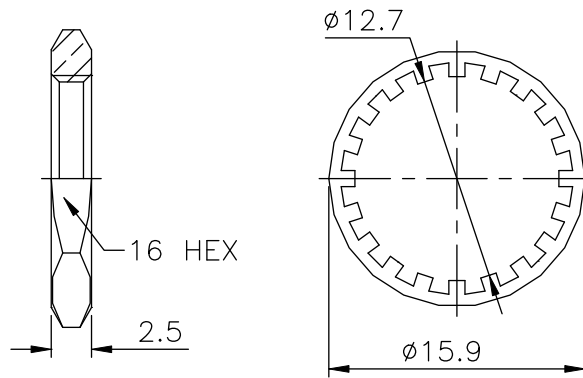

1. CRIMPED CONTACT PIN
HEX CRIMP SIZE .068" (1.72mm)
2. MAX. PANEL THICKNESS=4mm

UNLESS OTHERWISE SPECIFIED TOLERANCES

0.5-6	= ±0.2
>6-30	= ±0.4
>30-120	= ±0.6
>120-315	= ±1
>315-1000	= ±1.6
ANGLES	= ±5°

PANSTRONG COMPANY LTD.				DRAWN BY		TOMMY	
				CHECKED			
TITLE:		BNC BULKHEAD DIRECT SOLDER JACK (FOR .141")				APPROVED	
PART NO:		BF02N0205C				DRAW NO	
File Number:							
SCALE	2:1	REV	A1	UNIT	mm		