

REV	DESCRIPTION	DATE
A	Initial Release	06'.07.31

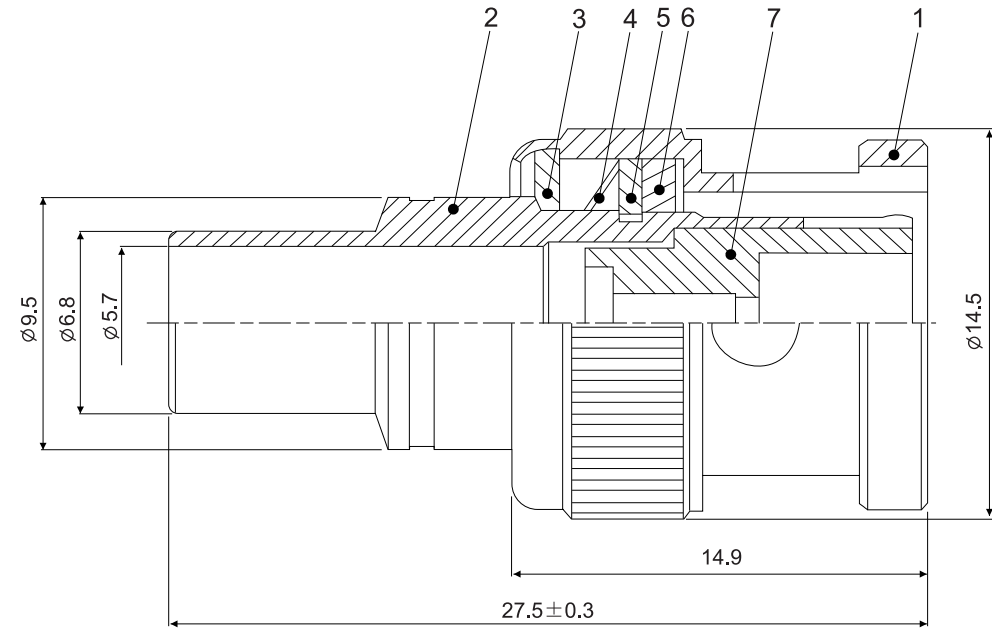
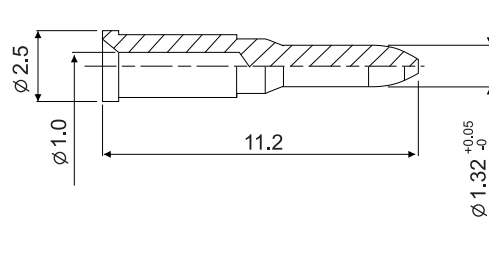

8	PIN	BRASS	GOLD	1
7	INSULATOR	DELFIN	WHITE	1
6	GASKET	RUBBER	REO	1
5	WASHER	STEEL	NICKEL	1
4	SPRING	SK-5	NICKEL	1
3	WASHER	STEEL	NICKEL	1
2	BODY	BRASS	NICKEL	1
1	SHEEL	BRASS	NICKEL	1
NO	DESCRIPTION	MATERIAL	FINISH	Q'TY

ROHS COMPLIANT

	PANSTRONG COMPANY LTD.			DRAWN BY	TOMMY
				CHECKED	
TITLE:	BNC MALE MOLDER & CRIMP RG58/U			APPROVED	
PART NO:	BM02N0217E			DRAWING NO.	
SCALE	/	REV	A	UNIT	mm