

REMARK: RoHS COMPLIANT

REV	DESCRIPTION	DATE
A1	Initial Release	06'.10.04

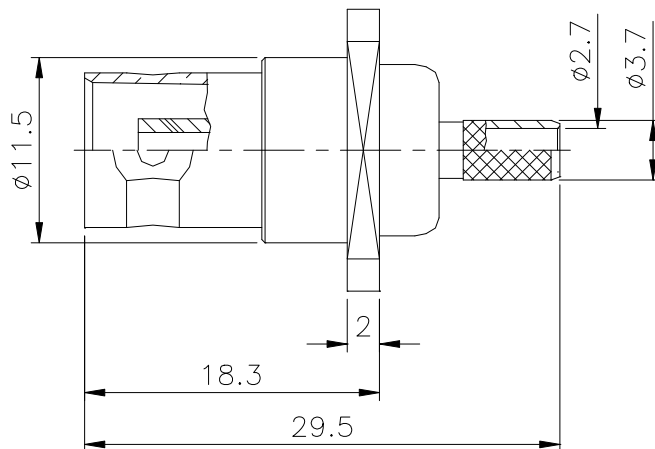

- FINISH (PLATING THICKNESS IN MICRO-INCHES)
1. BRASS PER QQ-B-626
  2. NICKEL PL 70 MIN THICK OVER COPPER STRIKE
  3. GOLD PL 3 MIN OVER NICKEL PL 70 MIN THICK OVER COPPER STRIKE
  4. PHOSPHOR BRONZE PER QQ-B-750
  5. TEFLON MIL-P-19468
  6. BRASS JIS H 3250, C 2700

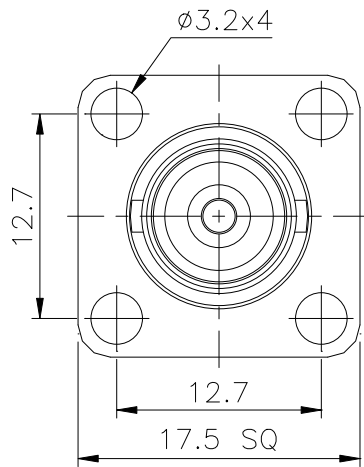
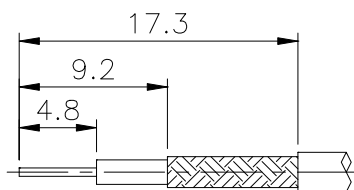
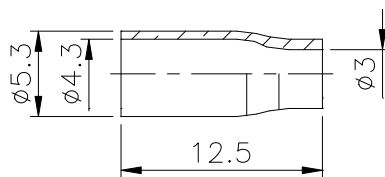
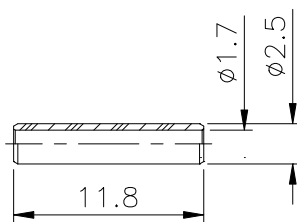
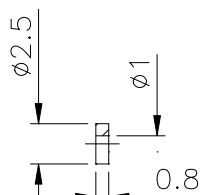
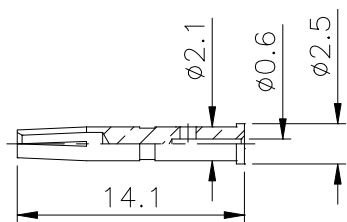

RECOMMENDED  
CABLE STRIPPING DIM'S

1. CRIMPED FERRULE  
HEX CRIMP SIZE .178" (4.52mm)

2. CRIMPED CONTACT PIN  
HEX CRIMP SIZE .068" (1.72mm)

UNLESS OTHERWISE SPECIFIED TOLERANCES

0.5~6	= ±0.2
>6~30	= ±0.4
>30~120	= ±0.6
>120~315	= ±1
>315~1000	= ±1.6
ANGLES	= ±5°

FERRULE	NOTE 6	NOTE 2
SPACER	NOTE 1	NOTE 2
SPACER	NOTE 5	WHITE
CONTACT PIN	NOTE 4	NOTE 3
PANEL	NOTE 1	NOTE 2
BRAID HOLDER	NOTE 1	NOTE 2
INSULATOR	DELRIN	WHITE
BODY	NOTE 1	NOTE 2
DESCRIPTION	MATERIAL	FINISH

<b>PANSTRONG COMPANY LTD.</b>				DRAWN BY		TOMMY	
				CHECKED			
TITLE:		BNC PANEL CRIMP JACK (FOR RG-174/U, 188A/U, 316/U)				APPROVED	
PART NO:		BF02N0211H4				DRAW NO	
File Number:							
SCALE	2:1	REV	A1	UNIT	mm		