

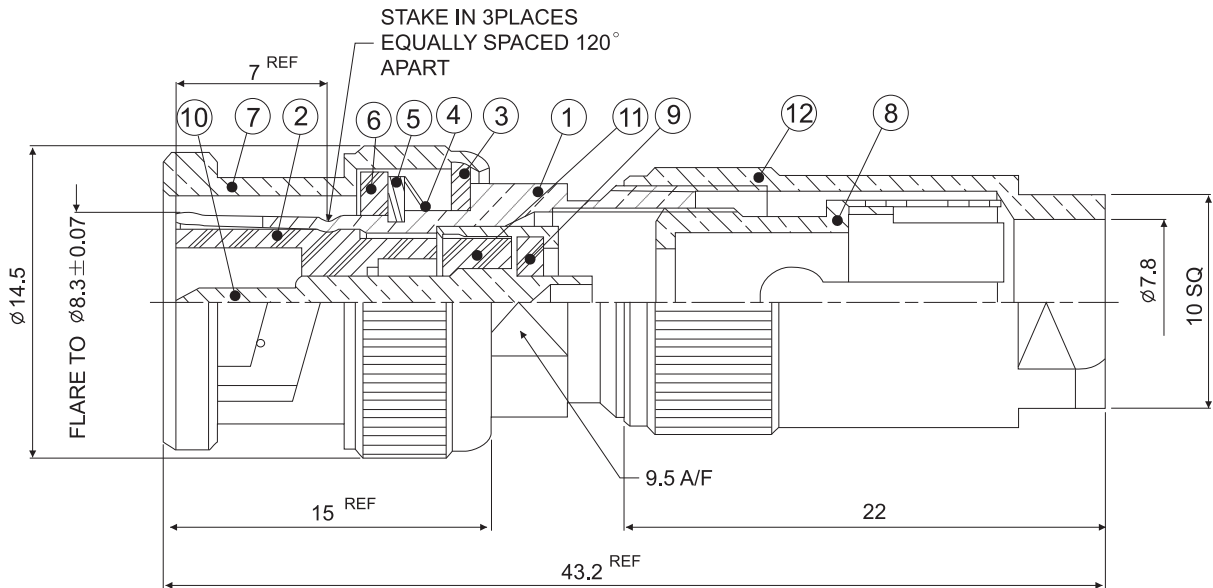

REV	DESCRIPTION	DATE
A	Initial Release	07'.06.04



FINISH(PLATING THICKNESS IN MICRO-INCHES)
 1.BRASS PER QQ-B-626
 2.NICKEL PL 70 MIN THICK OVER COPPER STRIKE
 3.GOLD PL FLUSH OVER NICKEL PL 70 MIN THICK OVER COPPER STRIKE
 4.TEFLON MIL-P-19468

12	SHELL	NOTE 1	NOTE 2	1
11	INSULATOR	NOTE 4	WHITE	1
10	CONTACT PIN	NOTE 1	NOTE 3	1
9	INSULATOR	NOTE 4	WHITE	1
8	BODY	NOTE 1	NOTE 2	1
7	SHELL	NOTE 1	NOTE 2	1
6	GASKET	RUBBER	RED	1
5	C RING	SS41	NOTE 2	1
4	SPRING	SK5	NOTE 2	1
3	WASHER	SS41	NOTE 2	1
2	INSULATOR	DELTRIN	WHITE	1
1	BODY	NOTE 1	NOTE 2	1
NO	DESCRIPTION	MATERIAL	FINISH	Q'TY

ROHS COMPLIANT

 PANSTRONG COMPANY LTD.	DRAWN BY	TOMMY
	CHECKED	
TITLE:	BNC CLAMP PLUG LOCK TYPE	
PART NO:	BM02N0212LKE(7014)	
SCALE	/	REV A
UNIT	mm	