

REV	DESCRIPTION	DATE
A	Initial Release	06'.12.15

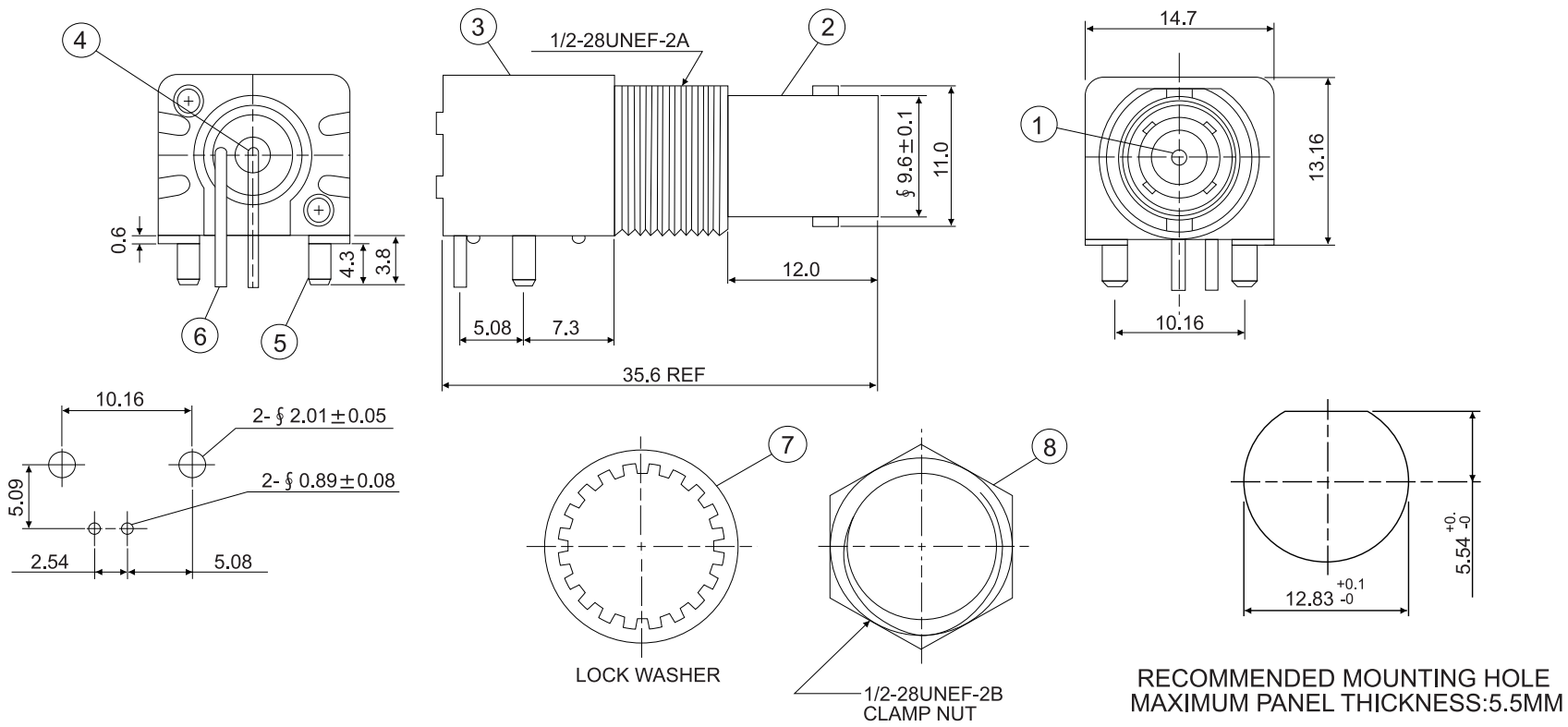

RECOMMENDED MOUNTING HOLE  
 MAXIMUM PANEL THICKNESS: 5.5MM

**MATERIAL & FINISH**

- 1. CENTER CONTACT : BRONZE, GOLD PLATING
- 2. BODY : ZINC ALLOY, NICKEL PLATING
- 3. HOUSING : PBT(94 V-0)
- 4. INSULATOR : PE-606
- 5. MOUNTING POST : BRONZE, TIN PLATING
- 6. SOLDER TAIL : COPPER WIRE, TIN PLATING
- 7. WASHER : STEEL, NICKEL PLATING
- 8. NUT : BRASS, NICKEL PLATING

ROHS COMPLIANT

	PANSTRONG COMPANY LTD.			DRAWN BY	TOMMY
				CHECKED	
TITLE:	50Ω BNC R/A PCB MOUNT JACK			APPROVED	
PART NO:	BF01X0401L3E			DRAWING NO.	
SCALE	2:1	REV	A	UNIT	mm

