

REV	DESCRIPTION	DATE
A	Initial Release	06'.08.16

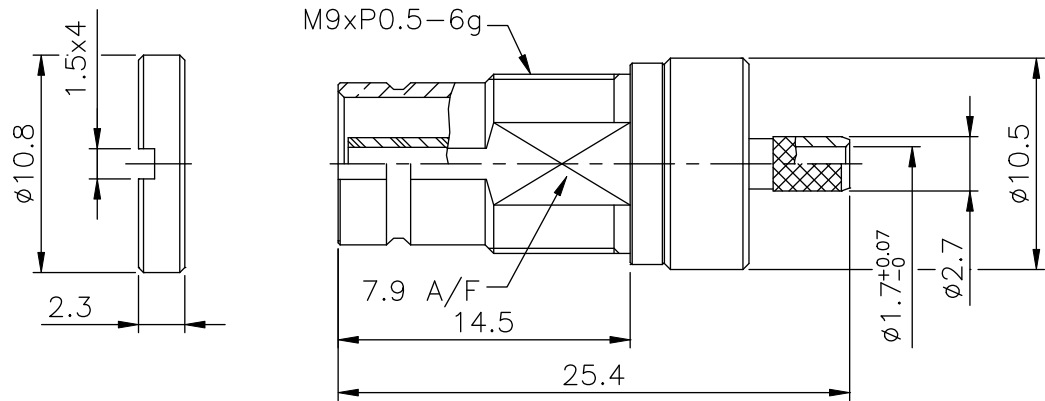

- FINISH (PLATING THICKNESS IN MICRO-INCHES)
1. BRASS PER QQ-B-626
  2. NICKEL PL 70 MIN THICK OVER COPPER STRIKE
  3. GOLD PL 3 MIN OVER NICKEL PL 70 MIN THICK OVER COPPER STRIKE
  4. TEFLON MIL-P-19468
  5. PHOSPHOR BRONZE PER QQ-B-750
  6. BRASS JIS H 3250, C 2700

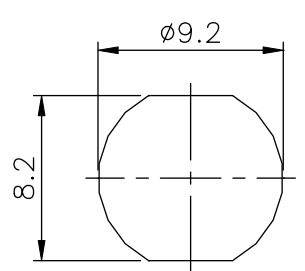

RECOMMENDED MOUNTING HOLE

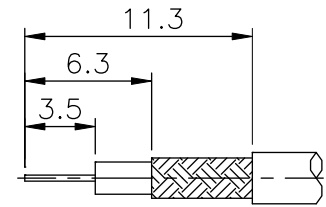

RECOMMENDED CABLE STRIPPING DIM'S

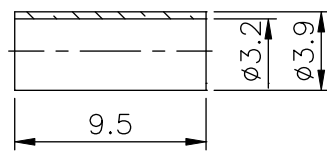

DESCRIPTION	MATERIAL	FINISH
NUT	NOTE 1	NOTE 2
FERRULE	NOTE 6	NOTE 2
CONTACT PIN	NOTE 5	NOTE 3
BRAID HOLDER	NOTE 1	NOTE 2
INSULATOR	NOTE 4	WHITE
BODY	NOTE 1	NOTE 3

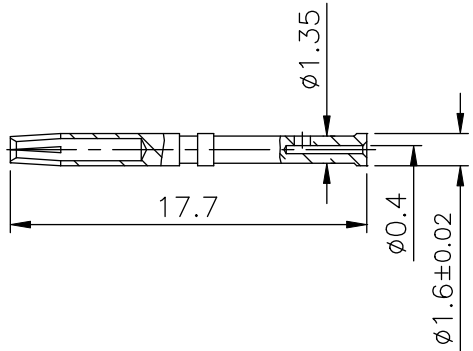

1. CRIMPED FERRULE  
HEX CRIMP SIZE .128" (3.25mm)
2. CRIMPED CONTACT PIN  
SQ. CRIMP SIZE .042" (1.07mm)
3. MAX. PANEL THICKNESS=2.5mm

RoHS COMPLIANT

UNLESS OTHERWISE SPECIFIED TOLERANCES

0.5-6	= ±0.2
6-30	= ±0.4
>30-120	= ±0.6
>120-315	= ±1
>315-1000	= ±1.6
ANGLES	= ±5°

PANSTRONG COMPANY LTD.				DRAWN BY		TOMMY	
				CHECKED			
TITLE:				1.6/5.6 BULKHEAD CRIMP JACK (FOR RG-179/U,179B/U,187A/U)			
PART NO:				1656F02N0111			
SCALE		2.5:1	REV	A	UNIT	mm	
APPROVED				DRAWING NO.			