

REV	DESCRIPTION	DATE
A	Initial Release	06'.08.18

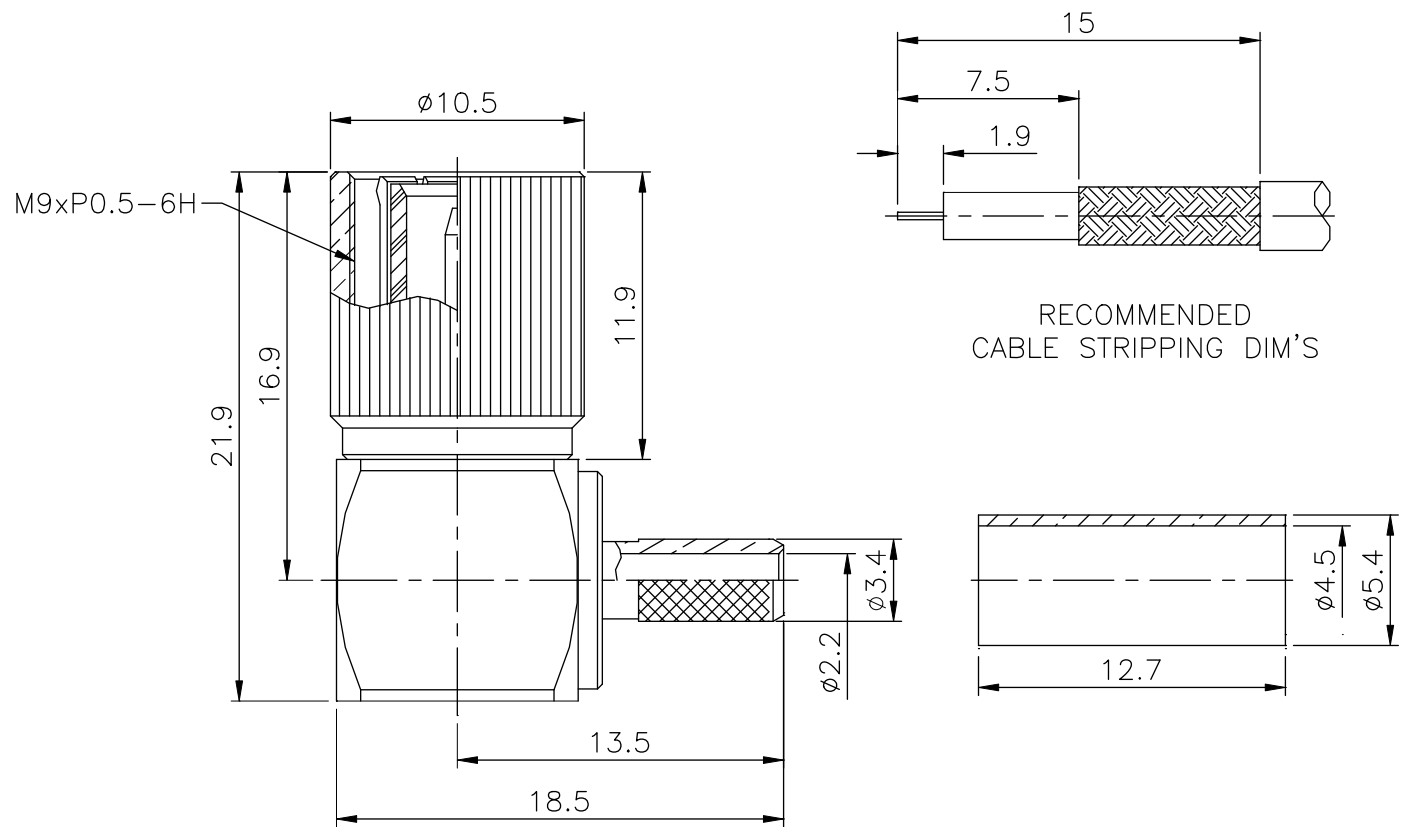

RECOMMENDED
CABLE STRIPPING DIM'S

- FINISH (PLATING THICKNESS IN MICRO-INCHES)
1. BRASS PER QQ-B-626
 2. NICKEL PL 70 MIN THICK OVER COPPER STRIKE
 3. GOLD PL 3 MIN OVER NICKEL PL 70 MIN THICK OVER COPPER STRIKE
 4. TEFLON MIL-P-19468
 5. PHOSPHOR BRONZE PER QQ-B-750
 6. BRASS JIS H 3250, C 2700

DESCRIPTION	MATERIAL	FINISH
FERRULE	NOTE 6	NOTE 2
COVER	NOTE 1	NOTE 2
INSULATOR	DELTRIN	NATURAL
CONTACT BODY	NOTE 5	NOTE 3
CONTACT PIN	NOTE 1	NOTE 3
INSULATOR	NOTE 4	WHITE
CUBE BODY	NOTE 1	NOTE 2
BODY	NOTE 1	NOTE 2
SHELL	NOTE 1	NOTE 2

1. CRIMPED FERRULE
HEX CRIMP SIZE .178" (4.52mm)
2. CONTACT PIN TO SOLDER

RoHS COMPLIANT

UNLESS OTHERWISE SPECIFIED
TOLERANCES

0.5-6	= ±0.2
>6-30	= ±0.4
>30-120	= ±0.6
>120-315	= ±1
>315-1000	= ±1.6
ANGLES	= ±5°

PANSTRONG COMPANY LTD.				DRAWN BY		TOMMY	
				CHECKED			
TITLE:		1.6/5.6 R/A CRIMP PLUG (FOR BT3002)				APPROVED	
PART NO:		1656M01N0111				DRAWING NO.	
SCALE		3:1		REV		A	
UNIT		mm					