

REV	DESCRIPTION	DATE
A1	Initial Release	05.12.06

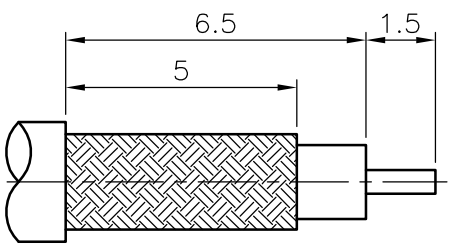

RECOMMENDED
CABLE STRIPPING DIM'S

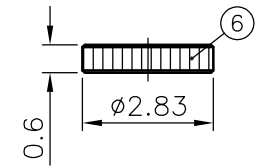
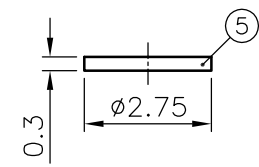
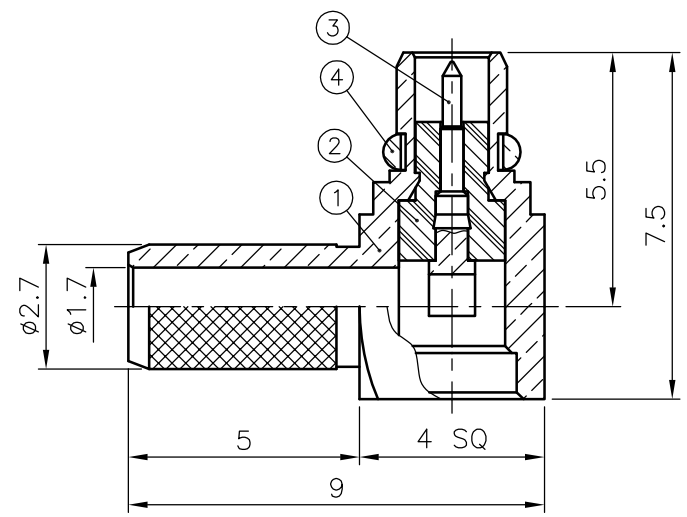
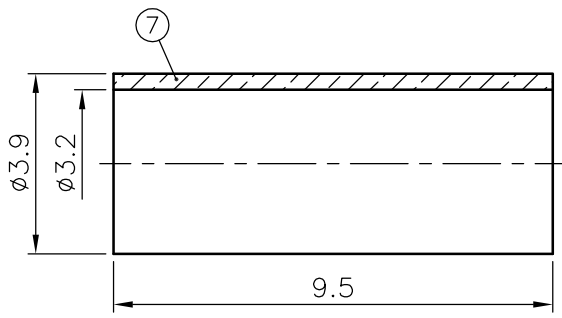

- 1. CRIMPED FERRULE
HEX CRIMP SIZE .128"
- 2. CONTACT PIN TO SOLDER

- FINISH (PLATING THICKNESS IN MICRO-INCHES)
- 1. BRASS PER QQ-B-626
 - 2. GOLD PL 3 MIN OVER NICKEL PL 70 MIN THICK OVER COPPER STRIKE
 - 3. GOLD PL 30 MIN OVER NICKEL PL 70 MIN THICK OVER COPPER STRIKE
 - 4. TEFLON MIL-P-19468
 - 5. BERYLLIUM COPPER PER QQ-C-530
 - 6. BRASS JIS H 3250, C 2700

7	FERRULE	NOTE 6	NOTE 2	1
6	COVER	NOTE 1	NOTE 2	1
5	INSULATOR	NOTE 4	WHITE	1
4	C RING	NOTE 5	NOTE 2	1
3	CONTACT PIN	NOTE 1	NOTE 3	1
2	INSULATOR	NOTE 4	WHITE	1
1	BODY	NOTE 1	NOTE 2	1
NO.	DESCRIPTION	MATERIAL	FINISH	Q'TY

PANSTRONG COMPANY LTD.		DRAWN BY		TOMMY		
		CHECKED				
TITLE:		MMCX R/A CRIMP PLUG (FOR RG-174/U,188A/U.316/U)		APPROVED		
PART NO:		MXM01G0111-174		DRAW NO		
DRAW. BOX NO:						
SCALE	6:1	REV	A1	UNIT	mm	