

REV	DESCRIPTION	DATE
A	Initial Release	07.03.26

FINISH(PLATING THICKNESS IN MICRO-INCHES)  
 1.BRASS PER QQ-B-626  
 2.GOLD PL 3 MIN OVER NICKEL PL 70 MIN THICK OVER COPPER STRIKE.  
 3.GOLD PL 30 MIN OVER NICKEL PL 70 MIN THICK OVER COPPER STRIKE  
 4.TEFLON MIL-P-19468  
 5.BERYLLIUM COPPER PER QQ-C-530  
 6.BRASS JIS H 3250, C 2700  
 7.GOLD PL FLUSH OVER NICKEL PL 70 MIN THICK OVER COPPER STRIKE

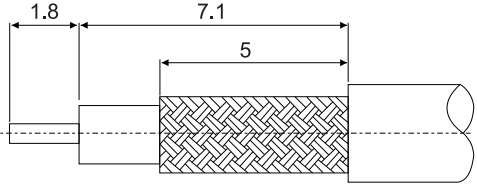

RECOMMENDED  
CABLE STRIPPING DIM'S

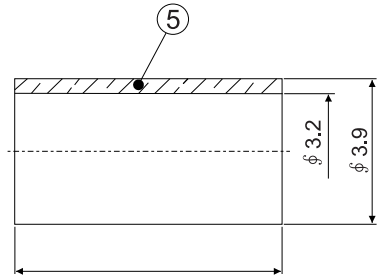
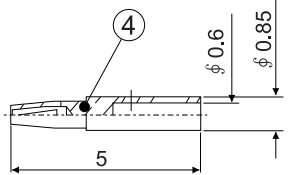
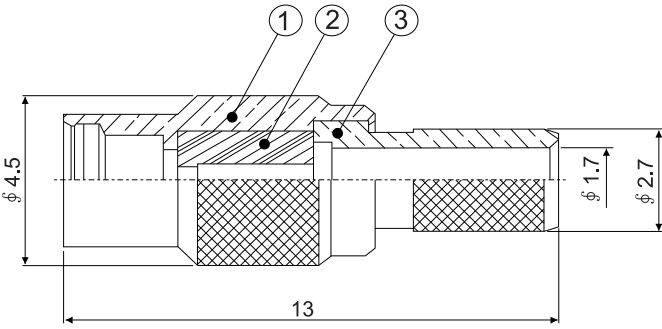

1.CRIMPED FERRULE  
HEX CRIMP SIZE .128"  
2.CONTACT PIN TO SOLDER

5	FERRULF	NOTE 6	NOTE 7	1
4	CONTACT PIN	NOTE 5	NOTE 3	1
3	BRAID HOLDER	NOTE 1	NOTE 2	1
2	INSULATOR	NOTE 4	WHITE	1
1	BODY	NOTE 1	NOTE 2	1
NO	DESCRIPTION	MATERIAL	FINISH	Q'TY

		DRAWN BY		TOMMY
		CHECKED		
TITLE:		MMCX CRIMP JACK (FOR RG174/U,188A/U,316/U)		APPROVED
PART NO:		MXF02G0111		DRAW NO
File Number:				
SCALE	/	REV	A	UNIT mm