

REV	DESCRIPTION	DATE
A	Initial Release	07.06.13

REMARK: RoHS COMPLIANT

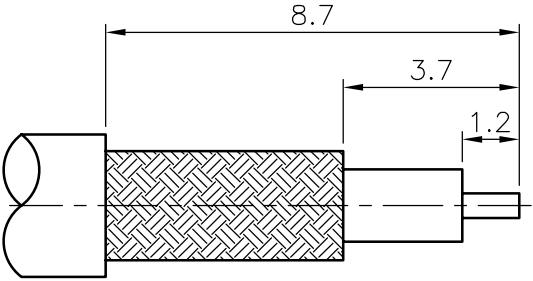

RECOMMENDED
CABLE STRIPPING DIM'S

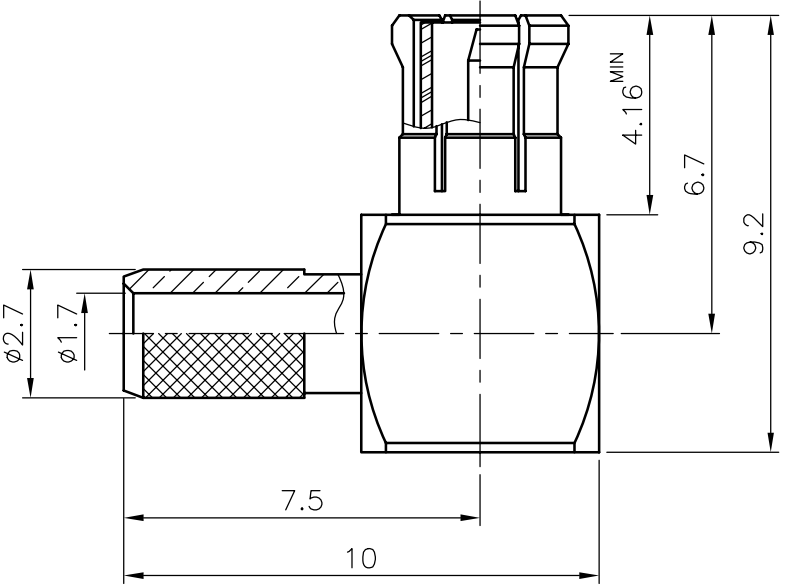
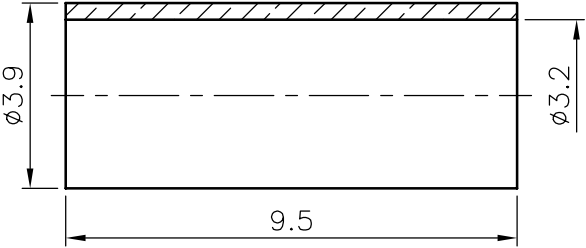

- FINISH (PLATING THICKNESS IN MICRO-INCHES)
- BRASS PER QQ-B-626
 - GOLD 3 MIN OVER NICKEL PL 70 MIN THICK OVER COPPER STRIKE
 - GOLD PL 30 MIN OVER NICKEL PL 70 MIN THICK OVER COPPER STRIKE
 - TEFLON MIL-P-19468
 - BERYLLIUM COPPER PER QQ-C-530
 - BRASS JIS H 3250, C 2700

- CRIMPED FERRULE
HEX CRIMP SIZE .128" (3.25mm)
- CONTACT PIN TO SOLDER

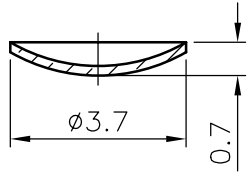

FERRULE	NOTE 6	NOTE 2
COVER	NOTE 1	NOTE 2
CONTACT BODY	NOTE 5	NOTE 2
INSULATOR	NOTE 4	WHITE
CONTACT PIN	NOTE 1	NOTE 3
CUBE BODY	NOTE 1	NOTE 2
DESCRIPTION	MATERIAL	FINISH

UNLESS OTHERWISE SPECIFIED TOLERANCES	
0.5-6	= ±0.2
>6-30	= ±0.4
>30-120	= ±0.6
>120-315	= ±1
>315-1000	= ±1.6
ANGLES	= ±5°

PANSTRONG COMPANY LTD.				DRAWN BY		TOMMY	
				CHECKED			
TITLE:		MCX R/A CRIMP PLUG (FOR RG-174/U, 188A/U, 316/U)				APPROVED	
PART NO:		XM01G0111				DRAW NO	
File Number:							
SCALE	6:1	REV	A	UNIT	mm		