

REV	DESCRIPTION	DATE
A	Initial Release	07.06.13

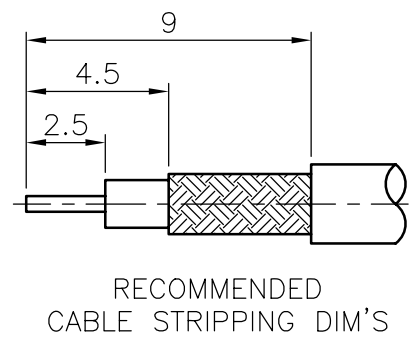

REMARK: RoHS COMPLIANT

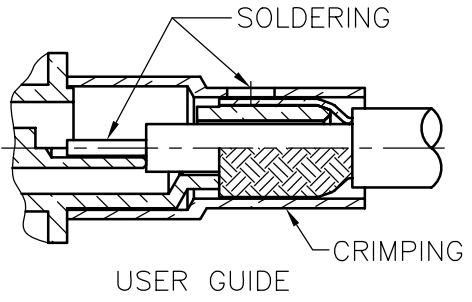
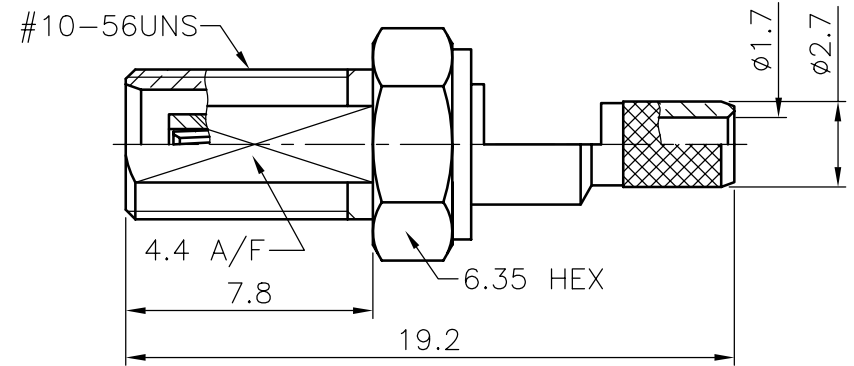
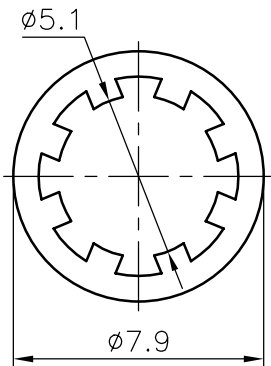
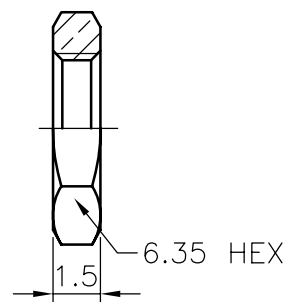
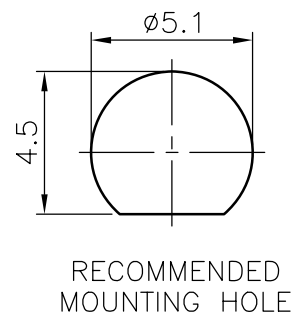

- FINISH (PLATING THICKNESS IN MICRO-INCHES)
- BRASS PER QQ-B-626
 - GOLD PL 3 MIN OVER NICKEL PL 70 MIN THICK OVER COPPER STRIKE
 - GOLD PL 30 MIN OVER NICKEL PL 70 MIN THICK OVER COPPER STRIKE
 - TEFLON MIL-P-19468
 - BERYLLIUM COPPER PER QQ-C-530
 - BRASS PER QQ-B-613

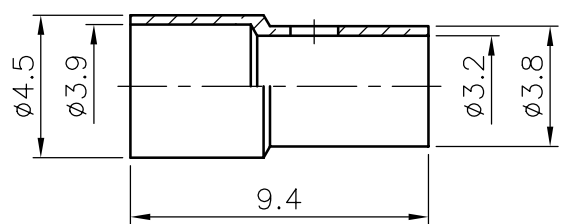

- CRIMPED FERRULE HEX CRIMP SIZE .128" (3.25mm)
- CONTACT PIN TO SOLDER
- MAX. PANEL THICKNESS=5.3mm

DESCRIPTION	MATERIAL	FINISH
NUT	NOTE 1	NOTE 2
WASHER	NOTE 6	NOTE 2
FERRULE	NOTE 1	NOTE 2
BRAID HOLDER	NOTE 1	NOTE 2
CONTACT PIN	NOTE 5	NOTE 3
INSULATOR	NOTE 4	WHITE
BODY	NOTE 1	NOTE 2

UNLESS OTHERWISE SPECIFIED TOLERANCES

0.5~6	= ±0.2
>6~30	= ±0.4
>30~120	= ±0.6
>120~315	= ±1
>315~1000	= ±1.6
ANGLES	= ±5°

PANSTRONG COMPANY LTD.				DRAWN BY		TOMMY	
				CHECKED			
TITLE:		MCX BULKHEAD CRIMP JACK (FOR RG-174/U,188A/U,316/U)				APPROVED	
PART NO:		XF02G0105C				DRAW NO	
File Number:							
SCALE	4:1	REV	A	UNIT	mm		