

REMARK: RoHS COMPLIANT

REV	DESCRIPTION	DATE
A1	Initial Release	07.04.02

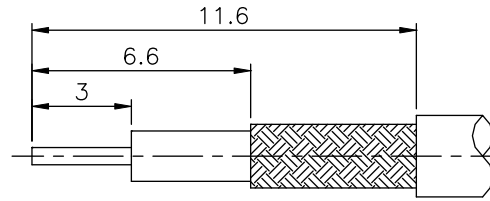

RECOMMENDED  
CABLE STRIPPING DIM'S  
(建議剝線尺寸)

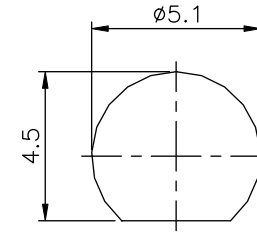

RECOMMENDED  
MOUNTING HOLE

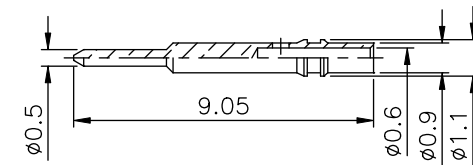
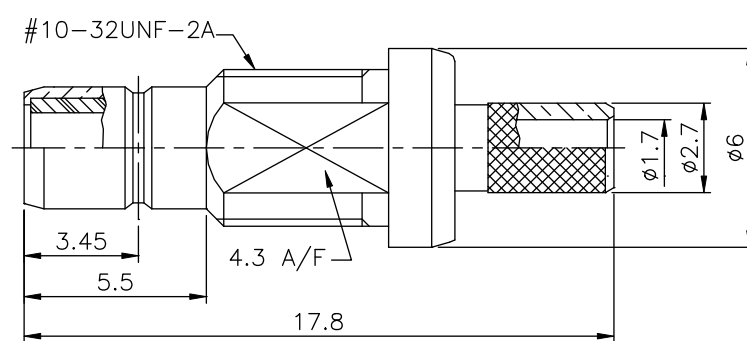
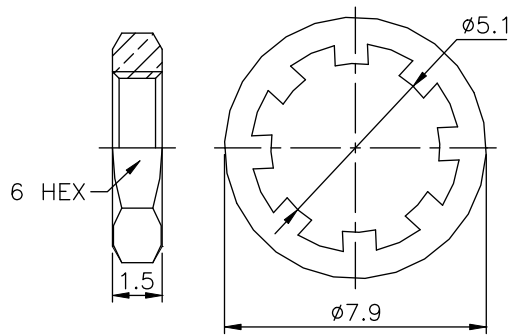

FINISH (PLATING THICKNESS IN MICRO-INCHES)

1. BRASS PER QQ-B-626
2. GOLD PL 3 MIN OVER NICKEL PL 70 MIN THICK OVER COPPER STRIKE
3. GOLD PL 30 MIN OVER NICKEL PL 70 MIN THICK OVER COPPER STRIKE
4. TEFLON MIL-P-19468
5. BRASS PER QQ-B-613
6. BRASS JIS H 3250, C 2700

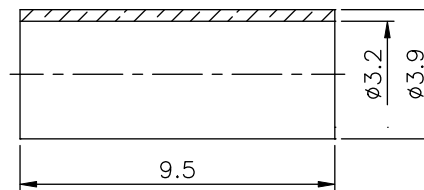

1. CRIMPED FERRULE  
HEX CRIMP SIZE .128" (3.25mm)
2. CONTACT PIN TO SOLDER
3. MAX. PANEL THICKNESS=3mm

FERRULE	NOTE 6	NOTE 2
NUT	NOTE 5	NOTE 2
WASHER	NOTE 1	NOTE 2
CONTACT PIN	NOTE 1	NOTE 3
BRAID HOLDER	NOTE 1	NOTE 2
INSULATOR	NOTE 4	WHITE
INSULATOR	NOTE 4	WHITE
BODY	NOTE 1	NOTE 2
DESCRIPTION	MATERIAL	FINISH

DIMENSIONS ARE IN MILLIMETERS  
UNLESS OTHERWISE SPECIFIED  
TOLERANCES

0.5-6	= ±0.2
>6-30	= ±0.4
>30-120	= ±0.6
>120-315	= ±1
>315-1000	= ±1.6
ANGLES	= ±5°

<b>PANSTRONG COMPANY LTD.</b>				DRAWN BY		TOMMY	
				CHECKED			
TITLE:		SMB BULKHEAD CRIMP JACK (FOR RG-174/U, 188A/U, 316/U)				APPROVED	
PART NO:		SMBF02G0105C				DRAW NO	
File Number:							
SCALE	/	REV	A1	UNIT	mm		