

REMARK: RoHS COMPLIANT

REV	DESCRIPTION	DATE
A	Initial Release	06'.08.03

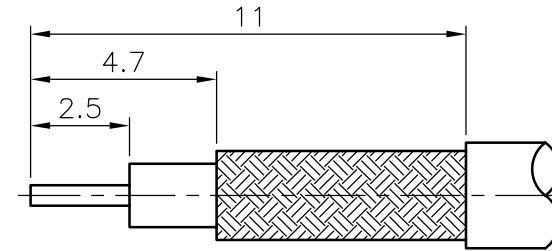

RECOMMENDED
CABLE STRIPPING DIM'S

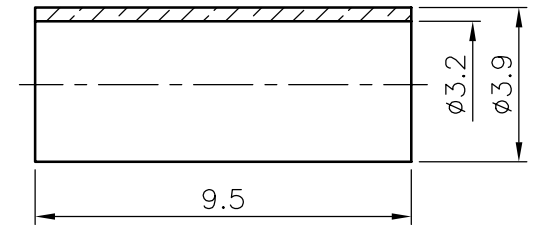
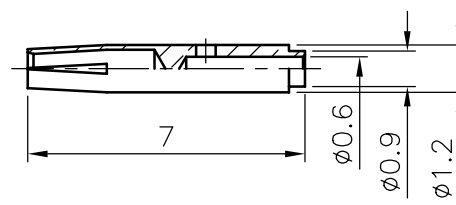
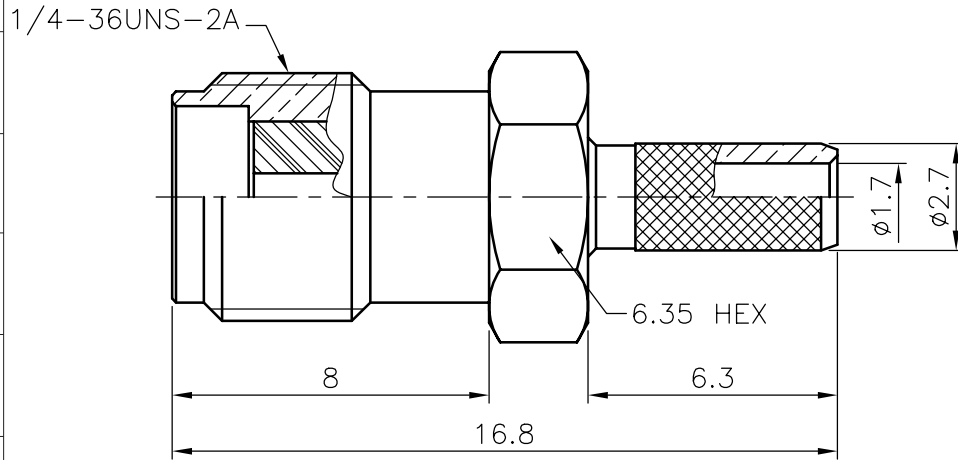

1. CRIMPED FERRULE
HEX CRIMP SIZE .128" (3.25mm)
2. CONTACT PIN TO SOLDER

FINISH (PLATING THICKNESS IN MICRO-INCHES)

1. BRASS PER QQ-B-626
2. GOLD PL 3 MIN OVER NICKEL PL 70 MIN THICK
OVER COPPER STRIKE
3. GOLD PL 30 MIN OVER NICKEL PL 70 MIN THICK
OVER COPPER STRIKE
4. TEFLON MIL-P-19468
5. BERYLLIUM COPPER PER QQ-C-530
6. BRASS JIS H 3250, C 2700

DESCRIPTION	MATERIAL	FINISH
FERRULE	NOTE 6	NOTE 2
CONTACT PIN	NOTE 5	NOTE 3
INSULATOR	NOTE 4	WHITE
BODY	NOTE 1	NOTE 2

UNLESS OTHERWISE SPECIFIED
TOLERANCES

0.5-6 = ±0.2
>6-30 = ±0.4
>30-120 = ±0.6
>120-315 = ±1
>315-1000 = ±1.6
ANGLES = ±5°

PANSTRONG COMPANY LTD.		DRAWN BY	TOMMY
		CHECKED	
TITLE:	SMA CRIMP PLUG (FOR RG-174/U,188A/U,316/U)		APPROVED
PART NO:	SMAF02G0111-316		DRAW NO
File Number:			
SCALE	5:1	REV	A
UNIT	mm		