

REV	DESCRIPTION	DATE
A	Initial Release	11'.12.28

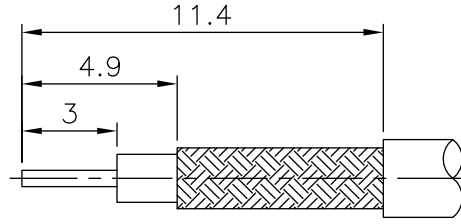

RECOMMENDED
CABLE STRIPPING DIM'S

- FINISH (PLATING THICKNESS IN MICRO-INCHES)
1. BRASS PER QQ-B-626
 2. GOLD PL 3 MIN OVER NICKEL PL 70 MIN THICK OVER COPPER STRIKE
 3. TEFLON MIL-P-19468
 4. PASSIVATED
 5. GOLD PL 30 MIN OVER NICKEL PL 70 MIN THICK OVER COPPER STRIKE
 6. BRASS JIS H 3250, C 2700

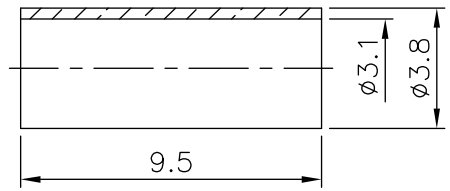
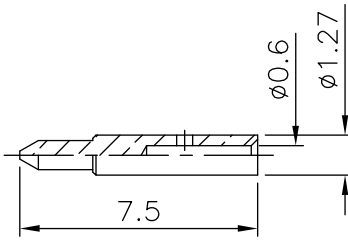
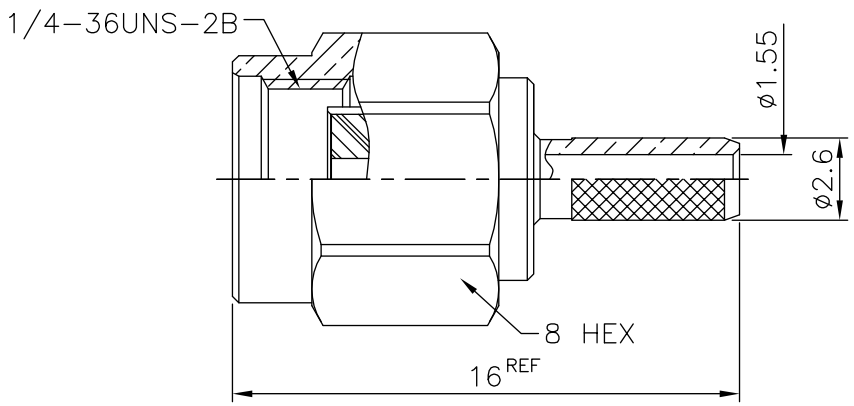

1. CRIMPED FERRULE
HEX CRIMP SIZE .128" (3.25mm)
2. CRIMPED CONTACT PIN
HEX CRIMP SIZE .042" (1.07mm)

FERRULE	NOTE 6	NOTE 2
CONTACT PIN	NOTE 1	NOTE 5
SHELL	NOTE 1	NOTE 2
GASKET	SILICONE	RED
C RING	SUS 304	NOTE 4
INSULATOR	NOTE 3	WHITE
BODY	NOTE 1	NOTE 2
DESCRIPTION	MATERIAL	FINISH

RoHS Compliant

PANSTRONG COMPANY LTD.				DRAWN BY		TOMMY		
				CHECKED				
TITLE:				SMA CRIMP PLUG (FOR RG-316/U)				
PART NO:				SMAM02G0111-316				
SCALE				4:1	REV	A	UNIT	mm
				APPROVED		DRAWING NO. 7811NS509BD014B		

DIMENSIONS ARE IN MILLIMETERS
UNLESS OTHERWISE SPECIFIED
TOLERANCES

0.5-6 = ±0.2
 >6-30 = ±0.4
 >30-120 = ±0.6
 >120-315 = ±1
 >315-1000 = ±1.6
 ANGLES = ±5'