

RECOMMENDED MOUNTING HOLE

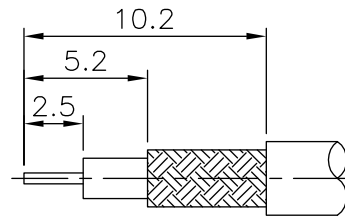

RECOMMENDED CABLE STRIPPING DIM'S

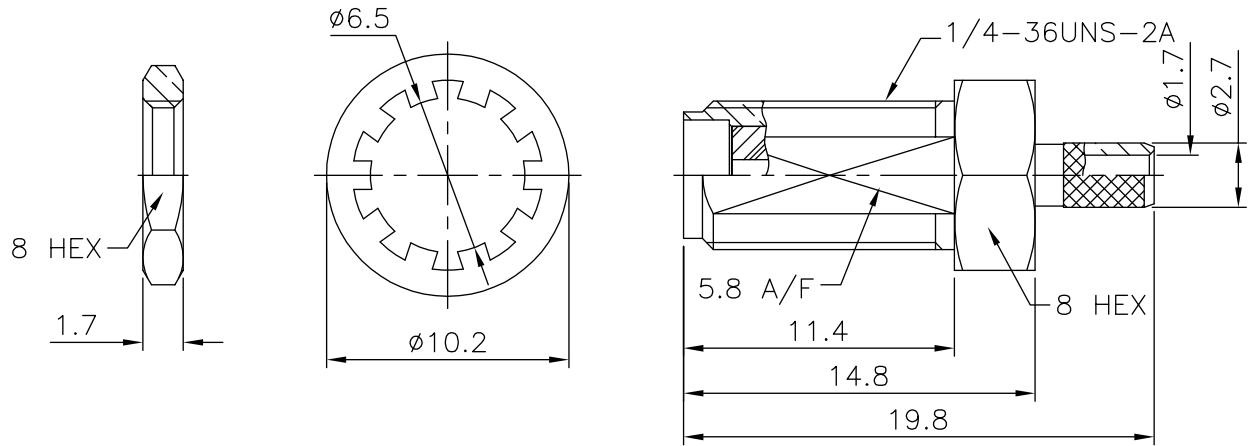

- FINISH (PLATING THICKNESS IN MICRO-INCHES)
1. BRASS PER QQ-B-626
 2. GOLD 3 MIN THICK OVER NICKEL PL 70 MIN THICK OVER COPPER STRIKE
 3. GOLD PL 30 MIN OVER NICKEL PL 70 MIN THICK OVER COPPER STRIKE
 4. TEFLON MIL-P-19468
 5. BERYLLIUM COPPER PER QQ-C-530
 6. COPPER JIS H 3300,C 1220
 7. BRASS PER QQ-B-613

NUT	NOTE 1	NOTE 2
WASHER	NOTE 7	NOTE 2
FERRULE	NOTE 6	NOTE 2
CONTACT PIN	NOTE 5	NOTE 3
INSULATOR	NOTE 4	WHITE
BODY	NOTE 1	NOTE 2
DESCRIPTION	MATERIAL	FINISH

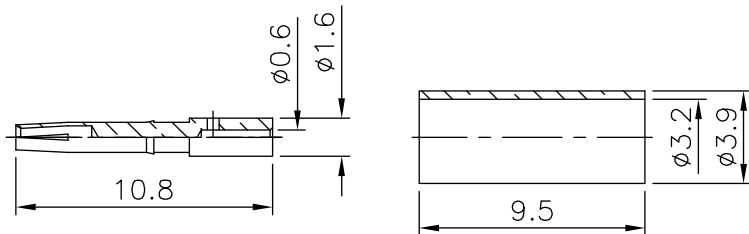

1. CRIMPED FERRULE HEX CRIMP SIZE .128" (3.25mm)
2. CONTACT PIN TO SOLDER
3. MAX. PANEL THICKNESS=3.2mm

RoHS COMPLIANT

DIMENSIONS ARE IN MILLIMETERS UNLESS OTHERWISE SPECIFIED TOLERANCES

0.5-6 = ±0.2
 6-30 = ±0.4
 30-120 = ±0.6
 120-315 = ±1
 315-1000 = ±1.6
 ANGLES = 45°

REV	DESCRIPTION	DATE
A1	P/N Transfer	06'.08.04
B1	Change Ferrule Material	09'.10.26
A2	Change Washer	10'.12.28

PANSTRONG COMPANY LTD.				DRAWN BY		TOMMY	
				CHECKED			
TITLE:		SMA BULKHEAD CRIMP JACK (FOR RG-174/U,188A/U,316/U)				APPROVED	
PART NO:		SMAF02G0105C				DRAWING NO. 7861BS509 BD000B	
SCALE		3:1		REV		A2	
UNIT		mm					