

REV	DESCRIPTION	DATE
A	Initial Release	20:07.02

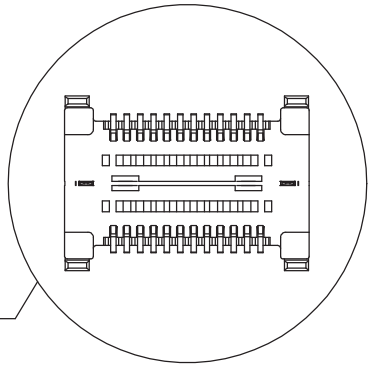
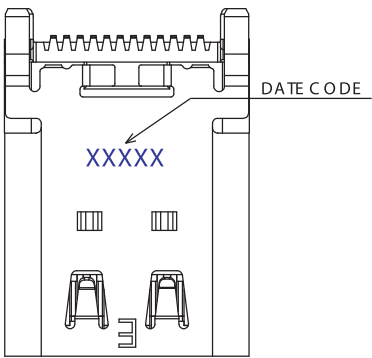

NOTES

- ELECTRICAL CHARACTERISTICS
 - LOW LEVEL CONTACT RESISTANCE
INITIAL : 40m FOR ALL CONTACT MAXIMUM.
AFTER TEST : 50m MAXIMUM.
 - DIELECTRIC WITHSTANDING VOLTAGE :
100V AC FOR 1 MINUTE SEA LEVEL
 - INSULATION RESISTANCE :
100M MINIMUM.
 - VUSB AND GND CONTACTS RATED AT 1.25A EA.
PARALLEL FOR A TO TAL OF 5A
- MECHANICAL CHARACTERISTICS :
 - INSERTION FORCE : 1~10000 CYCLES 5N~20N
 - EXTRACTION FORCE :
INITIAL EXTRACTION FORCE 6TH CYCLES OF 8N~20N.
1~5 INSERTION/EXTRACTION PRECONDITIONING CYCLES
DURABILITY 32TH EXTRACTION FORCE SHALL BE 33% OF THE INITIAL READING
(6 CYCLES ADDITIONAL 25 INSERTION/EXTRACTION CYCLES)
AFTER DURABILITY 10,000 CYCLES OF 6N~20N
 - DURABILITY : 10,000 CYCLES.
- OPERATING TEMPERATURE : -55°C TO +85°C

PART NO.
UB40CS33-24 F K XX X X R
1 2 3 4 5 6

- Contact Positions: 24: 24 Pins
- Contact Type: F: Female Receptacle
- Insulator Color: K: Black
- Contact Plating: 30: 30u" Selective Gold
- Shell Plating: N: Soldering Nickel
- Shell Pin Length (DIM C)
0: 1.0mm
1: 2.1mm

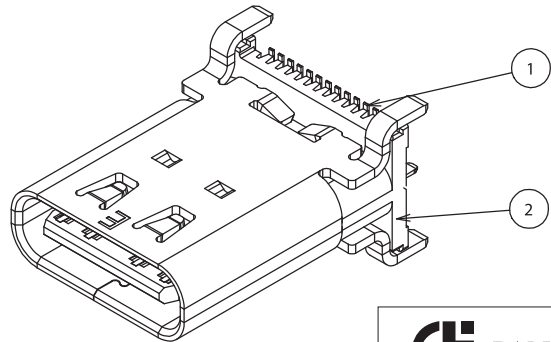
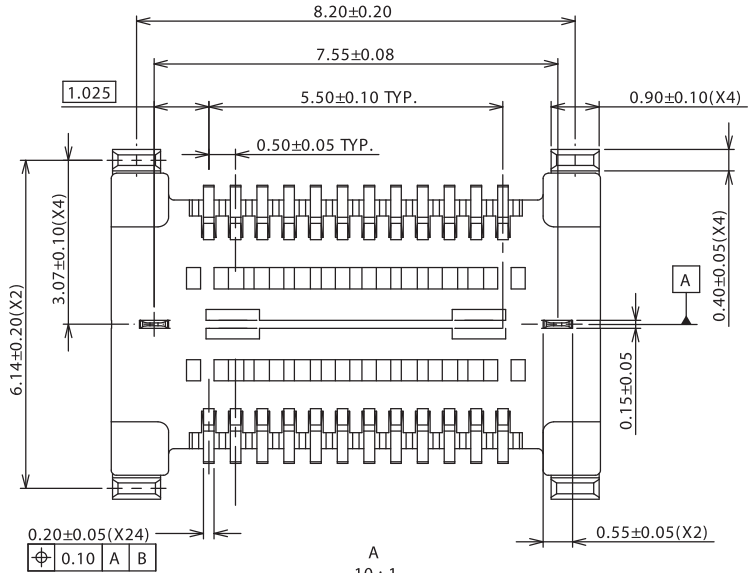
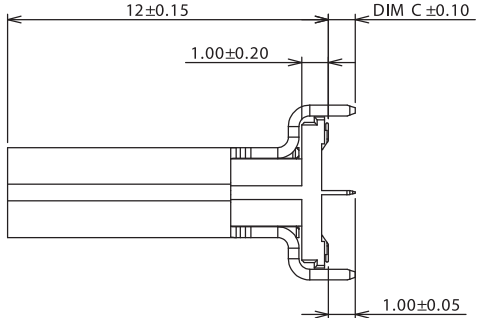
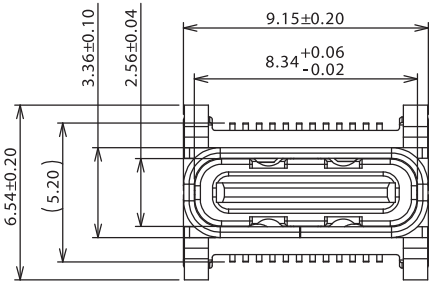

5	CAP	1	HI- TEMP.G.F.U94	V-0
4	SHELL	1	METAL / NI PLATIN	G
3	GND PLATE	1	METAL / NI PLATIN	G
2	HALF PRODUCT	1	HI- TEMP.G.F.U94	V-0
1	CONTACT	24	COPPER ALLOY AUP	LATING
ITEM	NAME	Q'TY	MATERIAL / FINIS	H

TOLERANCES UNLESS OTHERWISE SPECIFIED	
GENERAL	X ±0.38
	X ±0.25
	XX ±0.13
	XXX ±0.05
ANGLES	X* ±30°
	XX* ±20°
	XX* ±10°

				DRAWN BY		TOMMY	
				CHECKED		TOMMY	
TITLE:		USB4 TYPE C CONN. VERTIACL TYPE		APPROVED		CAROL	
PART NO:		UB40CS33-24FK		DRAWING NO.			
SCALE		5:1	REV	A	UNIT	mm	

REV	DESCRIPTION	DATE
A	Initial Release	20:07:02

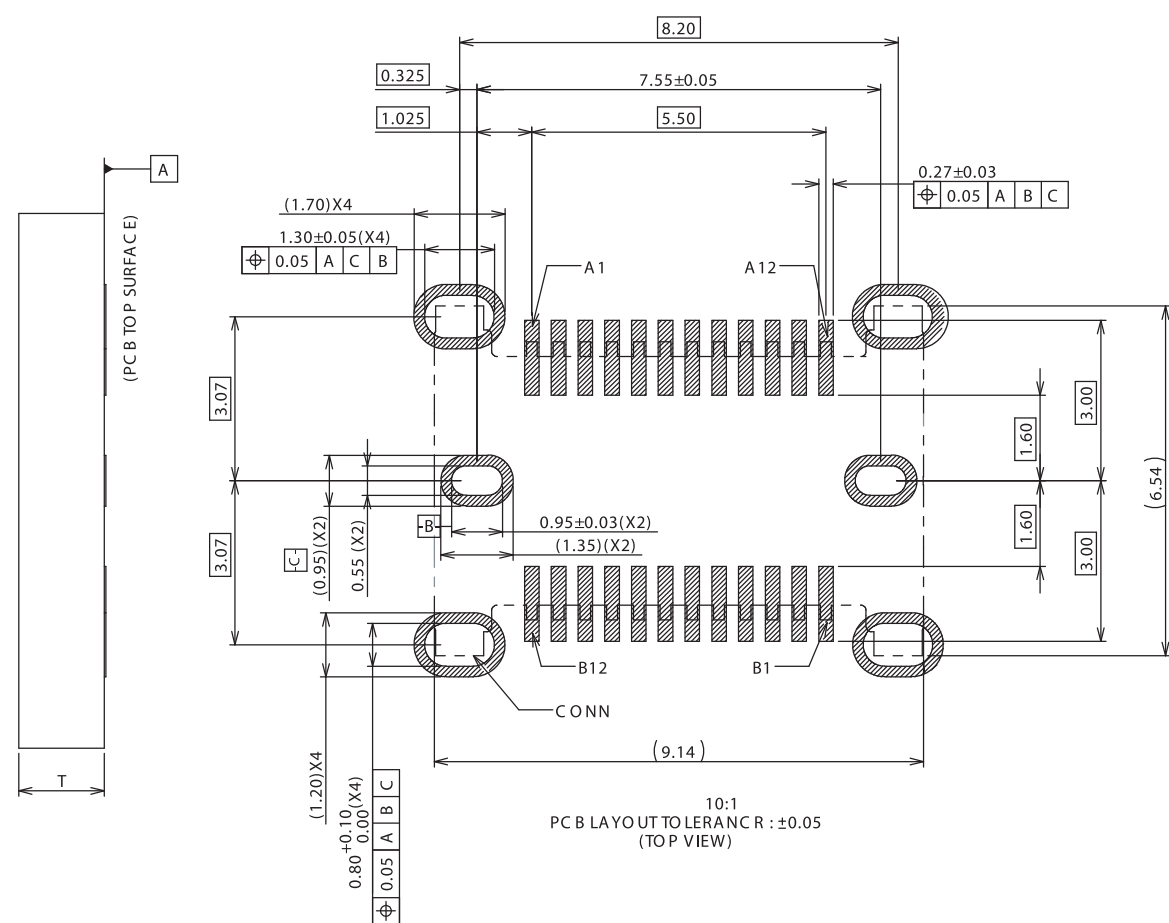

10:1
PCB LAYOUT TOLERANCE: ±0.05
(TOP VIEW)

PIN NO.	A1	A2	A3	A4	A5	A6	A7	A8	A9	A10	A11	A12
SIGNAL NAME	GND	TX1+	TX1-	VBUS	CC1	D+	D-	SBU1	VBUS	RX2-	RX2+	GND
PIN NO.	B12	B11	B10	B9	B8	B7	B6	B5	B4	B3	B2	B1
SIGNAL NAME	GND	RX1+	RX1-	VBUS	SBU2	D-	D+	CC2	VBUS	TX2-	TX2+	GND

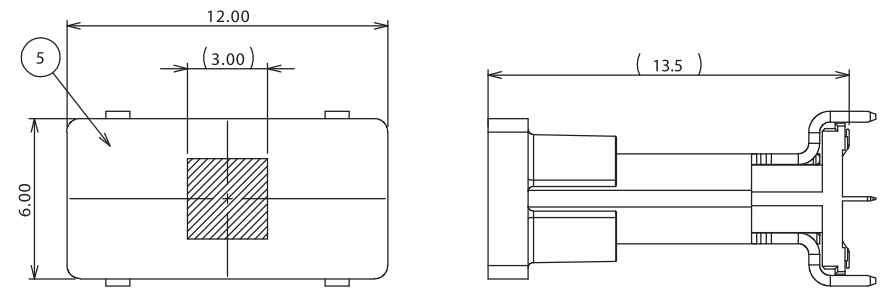

C AP ASSEMBLY C ONDITION (REF.)

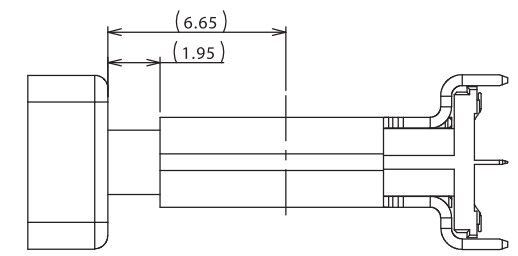

MATED C ONDITION (REF.)

TOLERANCES UNLESS OTHERWISE SPECIFIED

GENERAL	X	±0.38
	X	±0.25
	XX	±0.13
	XXX	±0.05
ANGLES	X*	±30°
	X*	±2°
	XX*	±1.0°

PANSTRONG COMPANY LTD.				DRAWN BY		TOMMY	
				CHECKED		TOMMY	
TITLE: USB4 TYPE C CONN. VERTIACL TYPE				APPROVED		CAROL	
				DRAWING NO.			
PART NO: UB40CS33-24FK		SCALE 5:1	REV A	UNIT mm			