

REV	DESCRIPTION	DATE
A	Initial Release	12'.10.25

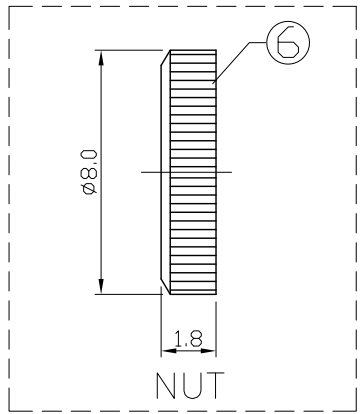
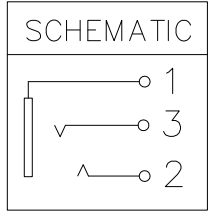
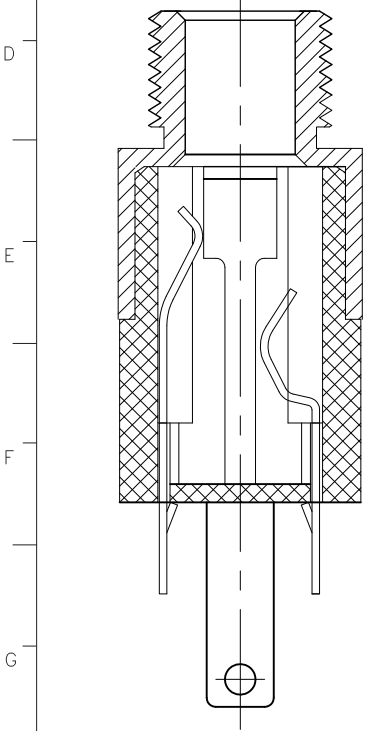
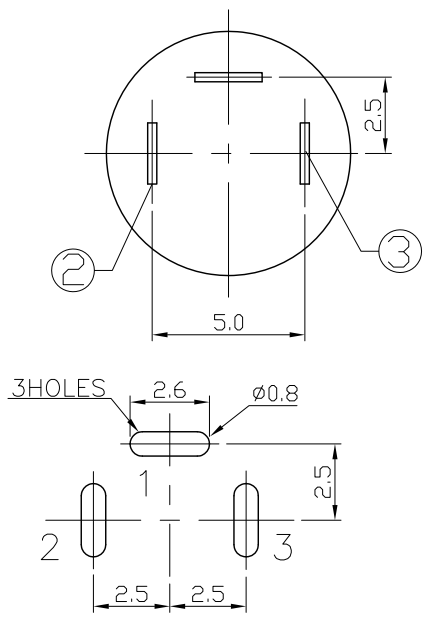
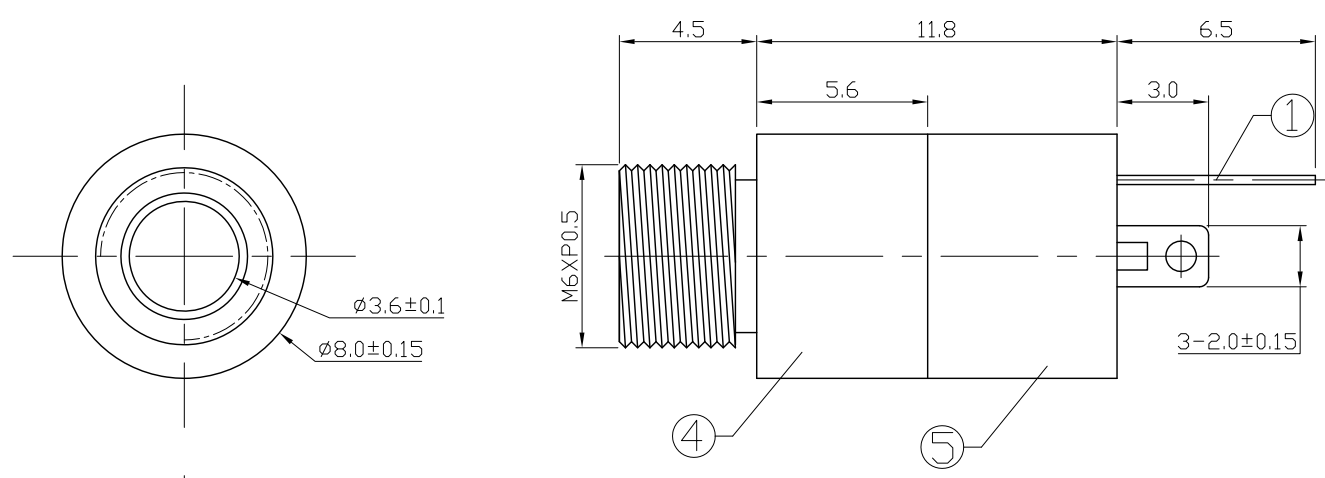

LEAD FREE

T:1.6 Dimensions of PC board holes
Tolerance : ±0.1(Printed-Top view)

6	NUT	1	H59(COPPER ALLOY)	MB:Cu Ni PLATED
5	HOUSING	1	PBT 4815	UL-94V0(BLACK)
4	AXIS SURPPORT	1	H59(COPPER ALLOY)	MB:Cu Ni PLATED
3	RING SPRING	1	C5191 t=0.30	MB:Ni Ag PLATED
2	TIP SPRING	1	C5191 t=0.30	MB:Ni Ag PLATED
1	EARTH SPRING	1	C2680 t=0.30	MB:Ni Ag PLATED
LTR	PART NAME	QTY	MATERIAL	REMARK

PANSTRONG COMPANY LTD.	DRAWN BY	TOMMY
	CHECKED	
TITLE:	3.5MM PHONE, DIP AND WIRE SOLDER VERTICAL	
PART NO:	PJ3.5-DP-77D	
SCALE	/	REV A
UNIT	mm	

UNLESS OTHERWISE SPECIFIED,
TOLERANCE ON DECIMAL:
±0.3

REV	DESCRIPTION	DATE
A	Initial Release	12'.10.25

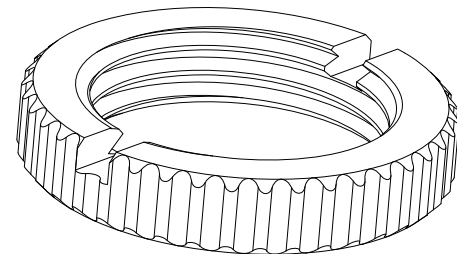
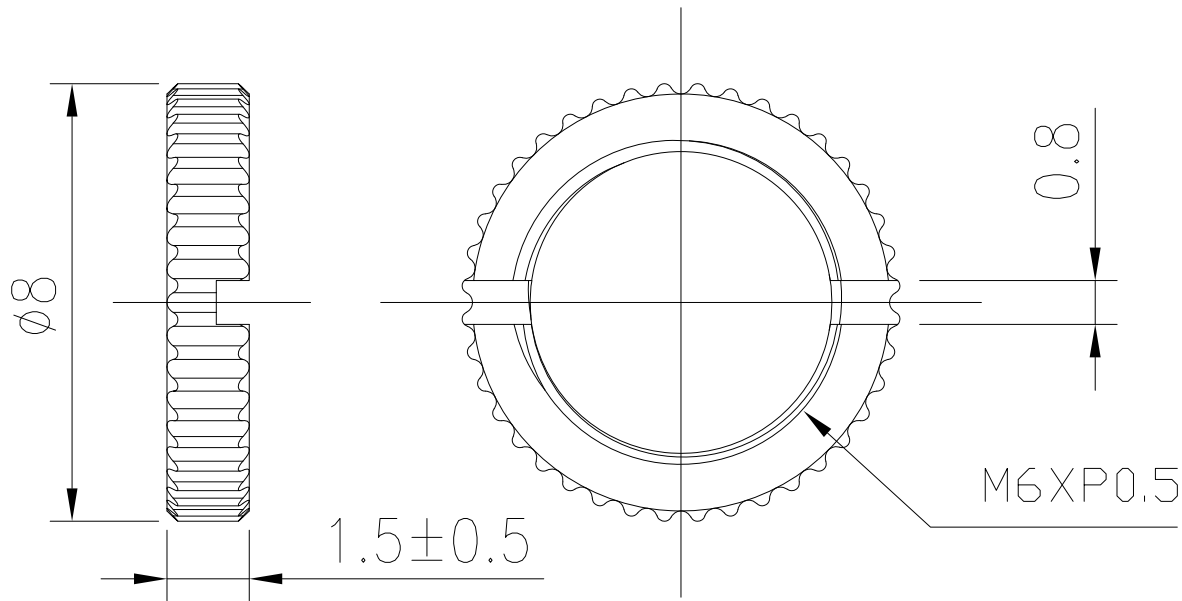
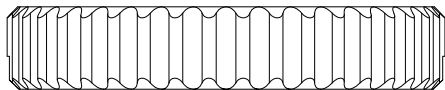

LEAD FREE

1	NUT	1	C2680	MB:Cu Ni PLATED
LTR	PART NAME	QTY	MATERIAL	REMARK

UNLESS OTHERWISE SPECIFIED,
TOLERANCE ON DECIMAL:
±0.3

PANSTRONG COMPANY LTD.				DRAWN BY		TOMMY	
				CHECKED			
TITLE:		ACCESSORY NUT FOR 3.5MM PHONE JACK				APPROVED	
PART NO:		PJ3.5-77-NUT				DRAWING NO.	
SCALE		/	REV	A	UNIT	mm	