

REV	DESCRIPTION	APPROVAL	DATE
A	Initial Release		07'.12.18

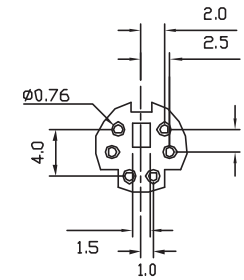
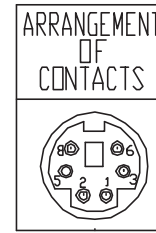
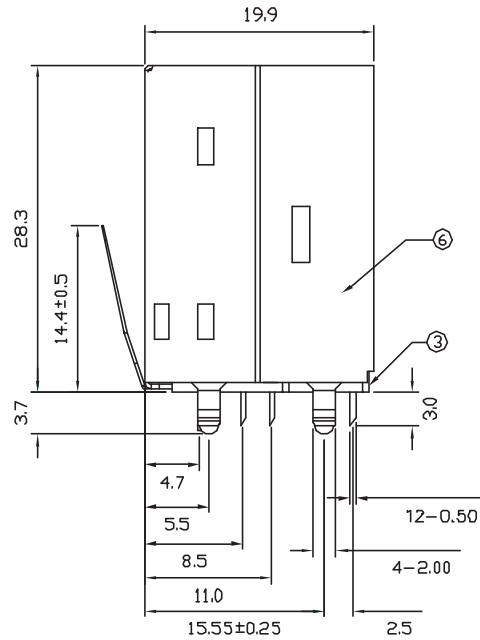
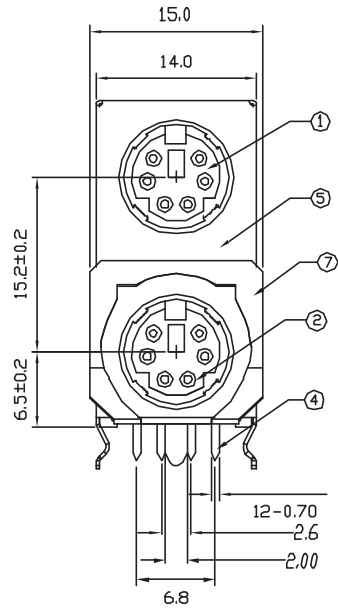

**Green Product**

**Specification:**

- Contact Resistance: 30m Ohm Max.
- Insulation Resistance: 100M Ohm Min. AT 500V DC
- Rated Voltage And Current: DC12V.2A Max; AC 100V.1A Max
- Dielectric Withstanding Voltage: 250V AC For 1 Minute
- Durability (Life Test): 100 Cycles
- Insertion Force: 4.0KG Maximum.
- Extraction Force: 0.9KG Minimum.

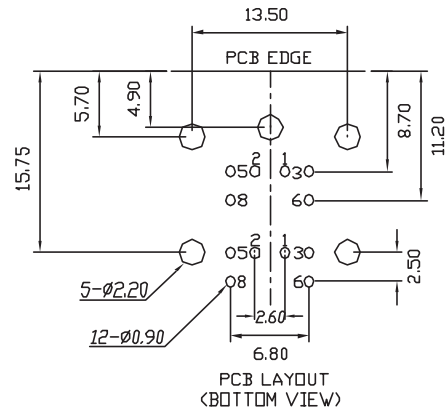

NO.	NAME	MATERIAL	FINISH	REMARK	Q'TY
1	TOP HOUSING	PBT G.F.	GREEN;3395C		1
2	BOTTOM HOUSING	PBT G.F.	PURPLE;2715C		1
3	BACK COVER	PBT G.F.	PURPLE;2715C		1
4	CONTACT TERM.	PHOS. BRONZE	GOLD/TIN PLATED	Gold:1~3u"; NI:40~60u"; TIN:120u" (100% pure Tin of lead free plating)	12
5	FRONT SHIELD	BRASS	TIN PLATED	TIN:120~200u"	1
6	BACK SHIELD	BRASS	TIN PLATED	TIN:120~200u"	1
7	GROUND SHIELD	STAINLESS	T: 0.2		1

TOLERANCE	
X.	±0.38
.X	±0.25
.XX	±0.13
.XXX	±0.05

				DRAWN BY		TOMMY	
				CHECKED			
TITLE:		MINI DIN JACK DUAL				APPROVED	
PART NO:		MDS01-6Fx2GP01-GS				DRAW NO	
File Number:						UNIT	
SCALE		1:1		REV		A	
				UNIT		mm	