

REV	DESCRIPTION	DATE
A	Initial Release	06.05.30

**Thumbscrew**

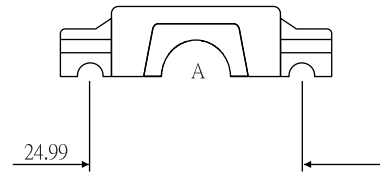

**Screw A**

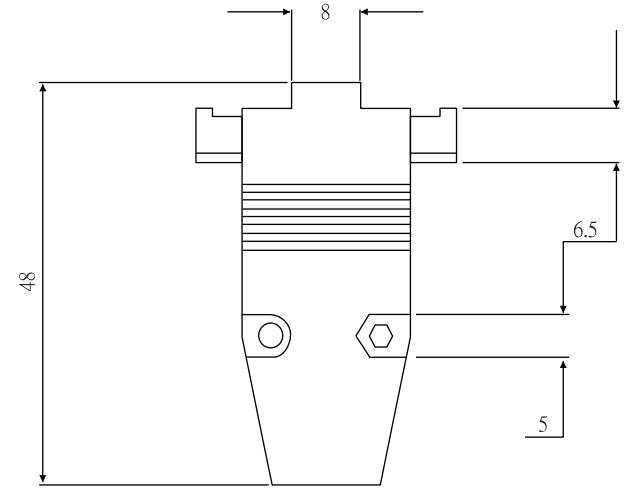
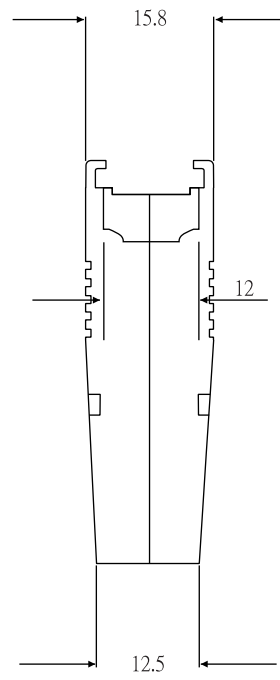
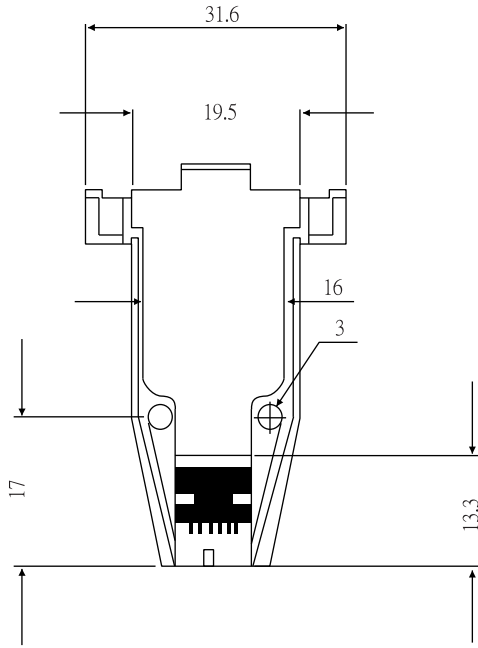
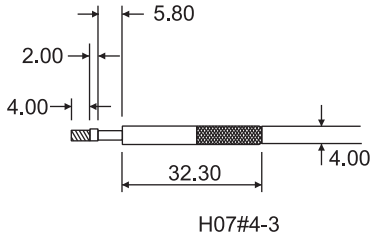
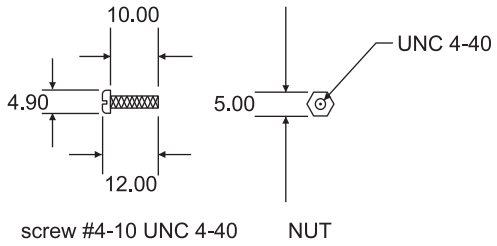

A: 5.5, 6, 6.5, 7, 7.5, 8, 8.5, 9, 9.5mm

**Screw B**

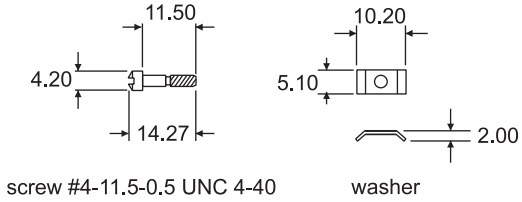

**Screw C**

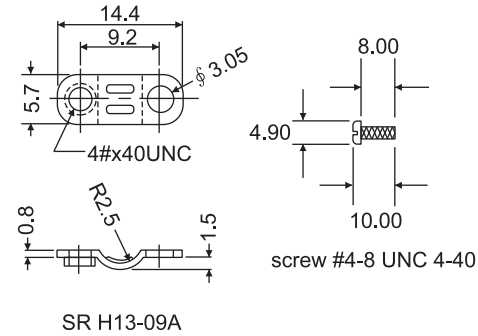

**Grommet**

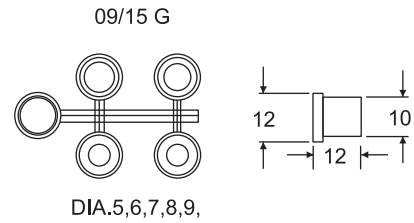

PART No.	Description
HS0904V	Screw A + Screw B
HS0904V01T	Screw A + Thumbscrew
HS0904V01SR	Screw A + Screw B + Screw C
HS0904V01TSR	Screw A + Screw C + Thumbscrew
Grommet 09/15	Grommet 09/15



PANSTRONG COMPANY LTD.

**DRAWN BY** TOMMY

**CHECKED**

**TITLE:**

D-Sub Hood

**APPROVED**

**PART NO:**

HS0904V01

**DRAWING NO.**

**SCALE**

/

**REV**

A

**UNIT**

mm

