

REV	DESCRIPTION	APPROVAL	DATE
C	新制定		06.05.09

REV.	DESCRIPTION	DATE
B	△B X2, AX2	03/25/05'
C	△C X2 AX2	04/02/05'

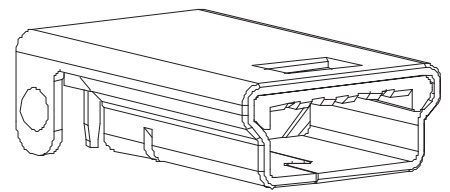
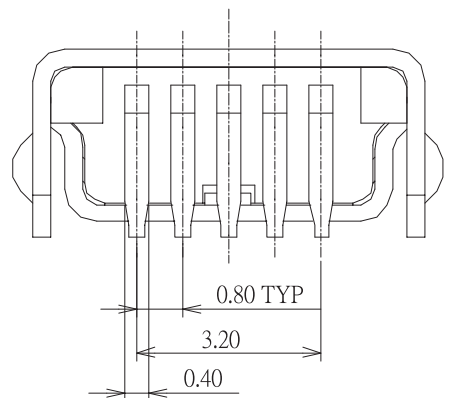
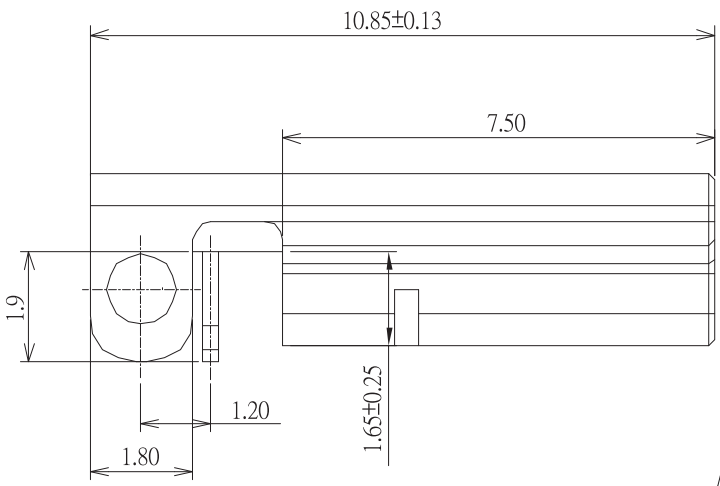
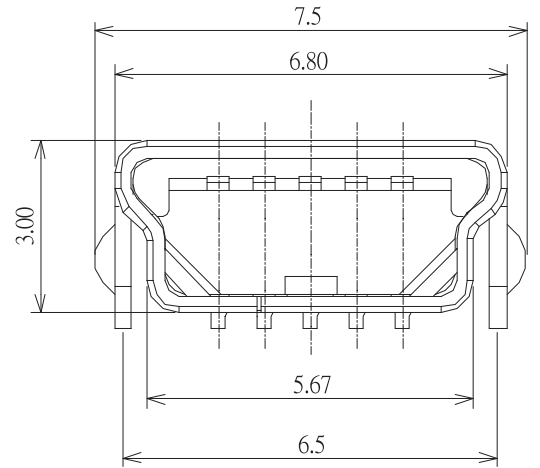
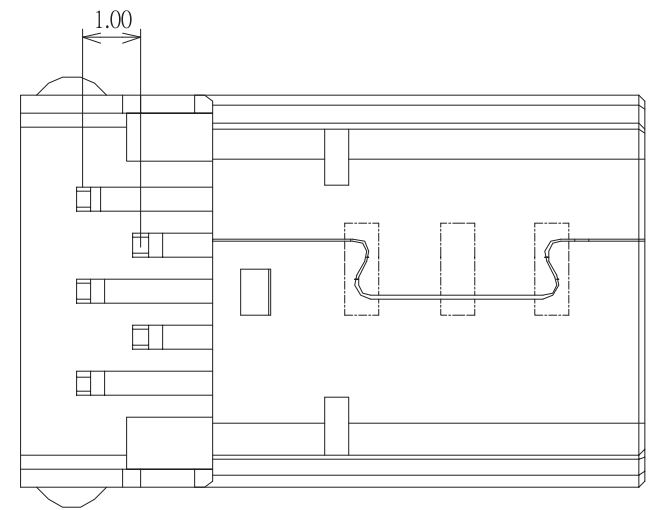
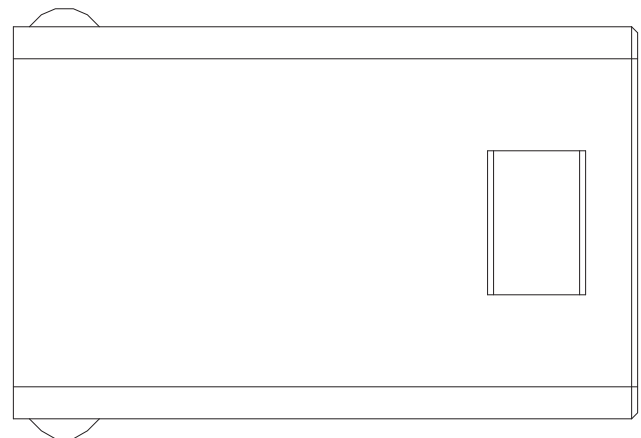

ROHS-COMPLIANT

ITEM	NAME	QTY	MATERIAL / FINISH
3	HOUSING	1	SEE PART NUMBERING CODE 6
2	CONTACT	5	JIS C2680 R-H, 30u" Au/ 100 ~ 200u" SN-CU
1	SHELL	1	JIS SPC-1, FINISH SEE PART NUMBERING CODE 5

GENERAL TOLERANCE		ANGLE TOLERANCE	
X.	±0.30	X.	±3.0°
.X	±0.25	.X	±2.0°
.XX	±0.13	.XX	±1.0°
.XXX	±0.05		

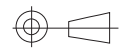
 <b>貝強實業有限公司</b> <b>PANSTRONG COMPANY LTD.</b>				DRAWN BY		<b>TOMMY</b>	
				CHECKED			
TITLE:		MINI USB B TYPE 5 POSITION LOW PROFILE R/A T/H (COUSTOMER DRAWING)				APPROVED	
PART NO:		<b>MUSBB5M0101K30</b>				DRAW NO	
DRAW. BOX NO:							
SCALE		<b>8:1</b>	REV	<b>C</b>	UNIT	<b>mm</b>	

REV	DESCRIPTION	APPROVAL	DATE
C	新制定		06.05.09

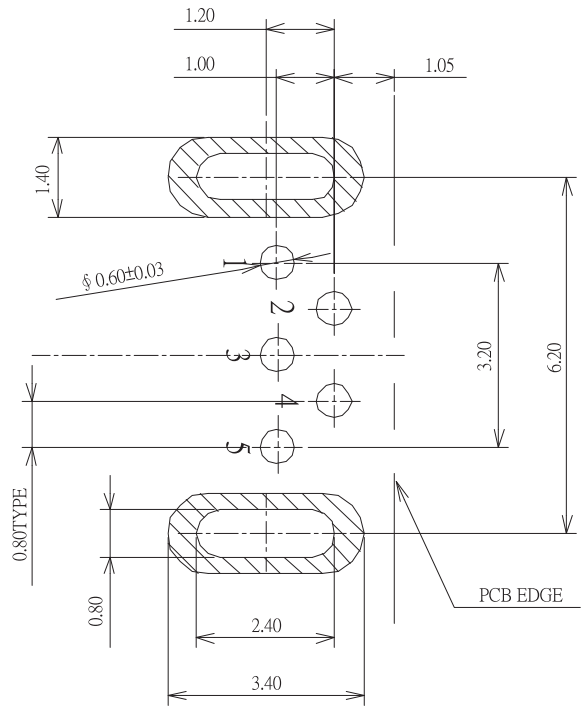

NOTE:1.0 RATING:  
 1.1 VOLTAGE: 30Vac (rms).  
 1.2 CURRENT: 1.0AMPERE AT 250VAC MINMUM.  
 1.3 TEMPERATURE: (REF TO CSP-MNC10-00-00)  
 2.0 ELECTRIC CHARACTERISTIC:  
 REFER TO PRODUCT SPEC.(CSP-MNC10-00-00)  
 3.0 METERIALS: (SEE TABLE B)  
 4.0 FINISHS: (SEE TABLE B)  
 5.0 OTHERS:  
 5.1 PRODUCT SPECIFICATION: CSP-MNC10-00-00  
 5.2 PRODUCT NUMBERING CODE: (SEE TABLE A)  
 5.3 RECOMMENED PC BOARD THICKNESS 1.2mm CR 1.57mm

TABLE A: PRODUCT NUMBER

MUSB	B	5	M	01	01	K	30
	1	2	3	4	5	6	7

1. MINI USB B TYPE
2. No. of Contact: 5 Positions
3. M: Plug
4. 01: Through-Hole
5. 01: Right Angle
6. Color of Insulation: K Black, W White
7. Plating of Contact: 30: 30u" Gold, 05: 05u"Gold

\*\*SHELL PLATING: NICKEL

FIGURE A: Printed Circuit Board (PCB) Layout (8:1)

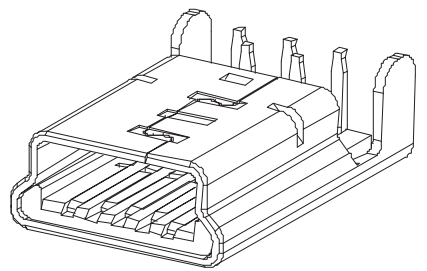
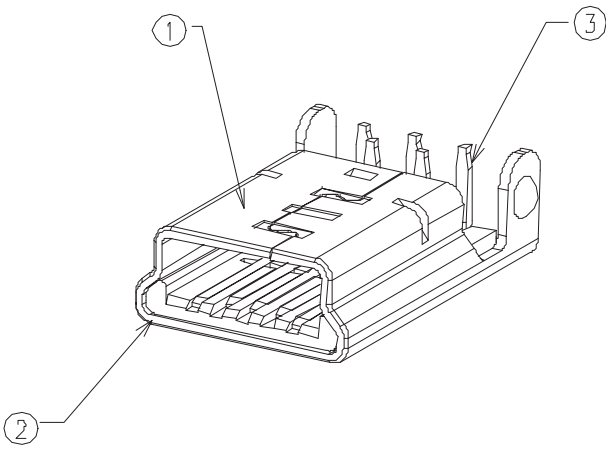

ROHS-COMPLIANT

GENERAL TOLERANCE		ANGLE TOLERANCE	
X.	±0.38	X.	±3.0°
.X	±0.25	.X'	±2.0°
.XX	±0.13	.XX'	±1.0°
.XXX	±0.05		

<b>貝強實業有限公司</b> <b>PANSTRONG COMPANY LTD.</b>				DRAWN BY		<b>TOMMY</b>	
				CHECKED			
TITLE:		MINI USB B TYPE 5 POSITION LOW PROFILE R/A T/H (CUSTOMER DRAWING)				APPROVED	
PART NO:		<b>MUSBB5M0101K30</b>				DRAW NO	
DRAW. BOX NO:							
SCALE		<b>8:1</b>	REV	<b>C</b>	UNIT	<b>mm</b>	