

REV	DESCRIPTION	DATE
A	Initial Release	15'.02.06
	⚠ X1, MX1	15'.03.09
	⚠ X5, AX3, MX2	15'.03.30
	⚠ X2, MX2	15'.05.02

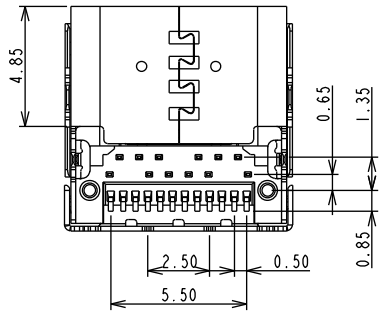
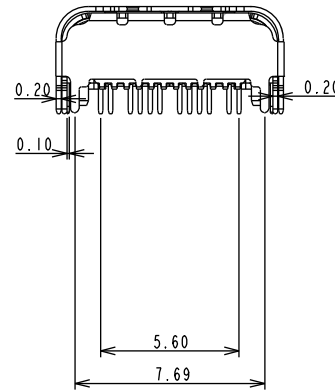
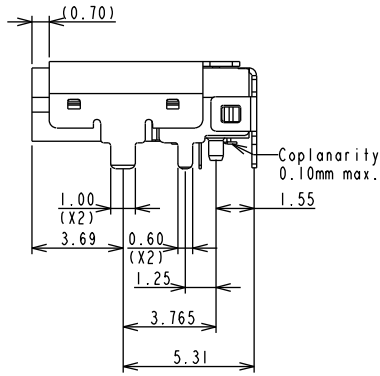
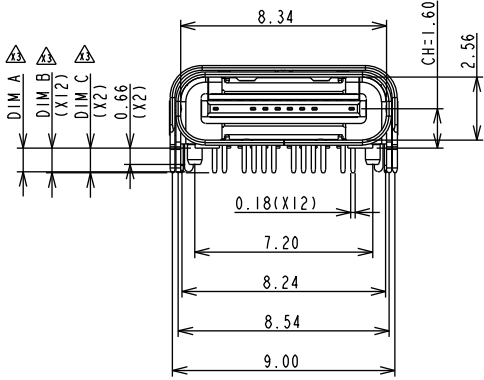
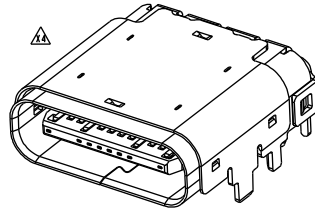
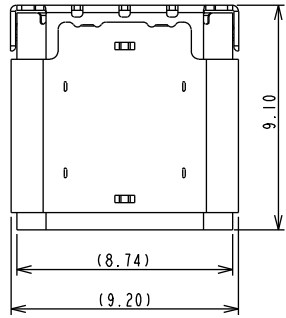

NOTES:

1.0. ELECTRICAL CHARACTERISTICS:

1.1. LOW LEVEL CONTACT RESISTANCE:
INITIAL: 40mΩ FOR ALL CONTACT MAX.
AFTER : 10mΩ MAX. CHANGE.

1.2. DIELECTRIC WITHSTANDING VOLTAGE:
100 VAC FOR 1 MINUTE SEA LEVEL.

1.3. INSULATION RESISTANCE:
100MΩ MIN.

1.4. CURRENT RATING:
VBUS AND GND CONTACTS RATED AT 1.25A EA.
PARALLELED FOR A TOTAL OF 5A

2.0. MECHANICAL CHARACTERISTICS:

2.1. INSERTION FORCE: 20N MAX

⚠ 2.2 EXTRACTION FORCE 1-1000 CYCLES 8N MIN. 20 N MAX.
EXTRACTION FORCE 1001-10000 CYCLES 6N MIN. 20 N MAX.

2.3. DURABILITY : 10,000 CYCLES

3.0 OPERATING TEMPERATURE: -55°C TO +85°

PART NO.

UB31CR31- 24 F K xx x x
1 2 3 4 5 6

1. Contact Positions:

24: 24 pins

2. Contact Type:

F: Female Receptacle

3. Insulator Color

K: Black

4. Contact Plating:

01: Selective G/F

30: Selective 30u" Gold

5. Shell Plating:

N: Solderable Nickel

6. Dip Pin Length (SEE TABLE C)

⚠ TABLE C : CONNECTOR DIP TYPE

PRODUCT NUMBERING	DIM A (Shell Dip)	DIM B (Contact Dip)	DIM C (Ground plate Dip)
UB31CR31-24FK***0	1.00mm	1.00mm	1.00mm
UB31CR31-24FK***2	1.80mm	1.60mm	1.40mm

ITEM	NAME	Q'TY	MATERIAL / FINISH
6	EMI RING	2	METAL / Ni PLATED
5	GROUND PLATE	1	METAL / Ni PLATED
4	SHELL	2	METAL / Ni PLATED
3	DOWN-CONTACT	12	COPPER ALLOY / Au PLATED
2	UP-CONTACT	12	COPPER ALLOY / Au PLATED
1	HALF PRODUCT	2	HI-TEMP. G.F. UL94V-0

TABLE B: PIN ASSIGNMENT

PIN NO.	A1	A2	A3	A4	A5	A6	A7	A8	A9	A10	A11	A12
SIGNAL NAME	GND	SSTXp1	SSTXn1	VBUS	CC1	Dp1	Dn1	SBU1	VBUS	SSRXn2	SSRXp2	GND
PIN NO.	B12	B11	B10	B9	B8	B7	B6	B5	B4	B3	B2	B1
SIGNAL NAME	GND	SSRXp1	SSRXn1	VBUS	SBU2	Dn2	Dp2	CC2	VBUS	SSTXn2	SSTXp2	GND

TOLERANCES UNLESS OTHERWISE SPECIFIED	
GENERAL X	±0.38
XX	±0.25
XXX	±0.05
ANGLES	
X°	±3.0°
XX°	±2.5°
XXX°	±1.5°

PANSTRONG COMPANY LTD.				DRAWN BY		TOMMY	
				CHECKED			
TITLE: USB TYPE-C CONN RECEPTACLE TOP MOUNT TYPE				APPROVED			
				DRAWING NO.			
PART NO: UB31CR31-24FK				UNIT	mm		
SCALE	1:1	REV	A				

REV	DESCRIPTION	DATE
A	Initial Release	15'.02.06
	△ X1, MX1	15'.03.09
	△ X5, AX3, MX2	15'.03.30
	△ X2, MX2	15'.05.02

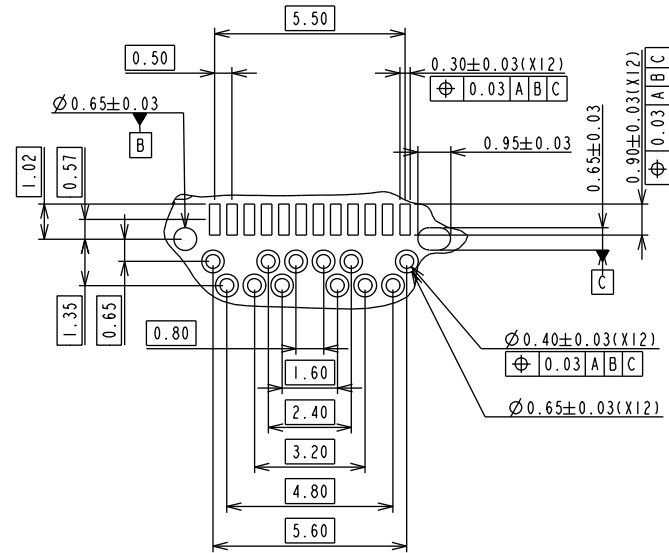
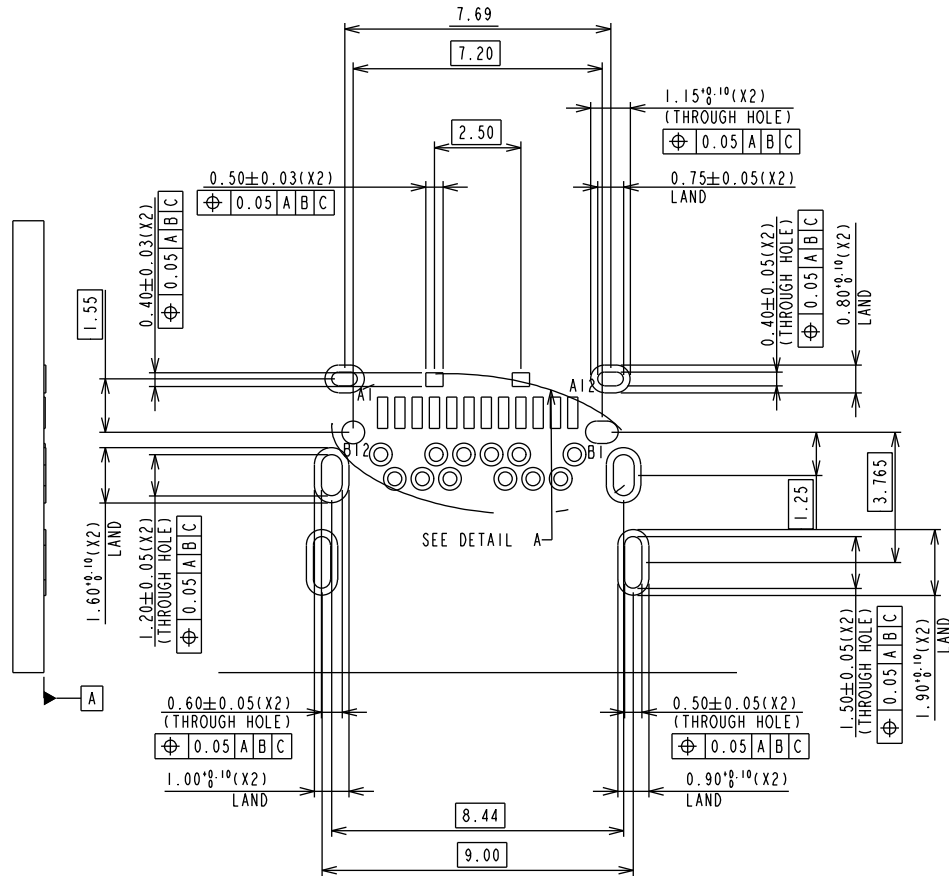

DETAIL A
SCALE 7:1

TOLERANCES UNLESS OTHERWISE SPECIFIED	
GENERAL	±0.38
XX	±0.25
XXX	±0.05
ANGLES	
°	±0.5°
'	±1.0'

 PANSTRONG COMPANY LTD.				DRAWN BY		TOMMY	
				CHECKED			
TITLE:				USB TYPE-C CONN RECEPTACLE TOP MOUNT TYPE			
PART NO:				UB31CR31-24FK			
SCALE		1:1	REV	A	UNIT	mm	